

# DESIGN OF A STRIP-LINE EXTRACTION KICKER FOR CTF3 COMBINER RING \*

I. Rodríguez<sup>#</sup>, L. García-Tabarés, F. Toral, CIEMAT, Madrid, Spain  
A. Ghigo, F. Marcellini, INFN, Frascati, Italy.

## Abstract

The new CLIC test facility (CTF3) is the latest stage to prove the technical feasibility of the CLIC project. An extraction kicker is necessary for the combiner ring, and it will be a strip-line type device due to lower coupling impedances and straightforward fabrication. The field uniformity together with a correct beam dynamics are the most challenging issues of this design. The main parameters of the kicker are analytically calculated using standard analytic formulae. The numeric modelling and simulation of several possible straight sections are reported, and the characteristic impedance is matched with the 50  $\Omega$  load. The field homogeneity, the kick angle and the scattering parameters are calculated in a 3D finite element model. Several manufacturing issues for the first prototype are also outlined.

## KICKER DESCRIPTION

Strip-line kickers consist of two long metallic parallel plates fed at the ends by two coaxial feedthroughs and generally supported by several insulators inside a beam pipe. The structure is similar to a pair of strip-lines where each electrode forms with a half beam pipe a transmission line of characteristic impedance  $Z_c = 50 \Omega$ . The characteristic impedance of the coaxial input and output ports must be matched with the load to avoid any reflection of the input power.

Table 1: Kicker and pulsed power supply specifications

MAGNITUDE	VALUE	UNITS
Max. Beam Energy	<b>300</b>	MeV
Deflection Angle	<b>8</b>	mrad
Transverse voltage $V_{\perp}$	<b>2.4</b>	MV
Rise/Fall-times (0-100%)	$\leq 70$	ns
Pulse length (max.)	<b>200</b>	ns
Flat-top reproducibility	$\pm 0.1$	%
Flat-top stability (incl. droop)	$\pm 0.25$	%
Repetition rate(Initial-Nominal)	<b>5-50</b>	Hz
Available length	<b>2000</b>	mm
Vertical aperture	$\geq 40$	mm
Horizontal aperture	$\geq 40$	mm
Field homogeneity area ( $< \pm 1\%$ )	<b>30</b>	mm

In order to generate a transverse kick, the kicker should be driven in differential mode, creating a TEM wave that exerts a combined Lorentz force over the charged particles.

As the particles are relativistic and in TEM propagation modes the modulus of  $E$  is related with  $B$  by the speed of light, the electric and magnetic components of the Lorentz force are identical.

Table 1 shows the latest specifications released by CTF3 team. Some of them are for the pulsed power supply, which is also strongly linked to the kicker.

## STRAIGHT SECTION DESIGN

Four possible straight sections have been considered to start with the design of the kicker. The characteristic impedance of each one has been calculated and optimized to 50  $\Omega$  with HFSS code [1] (see figs. 1 and 2). Lossless materials are used because the characteristic impedance is a geometrical parameter in vacuum working conditions.

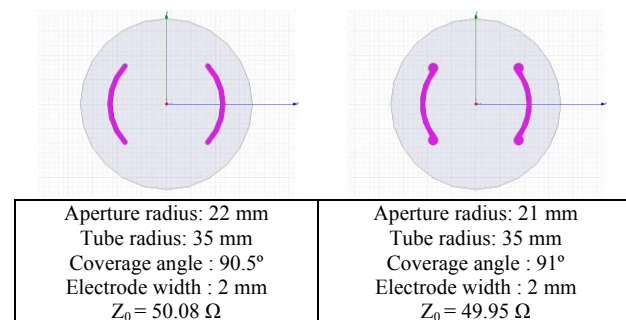

Figure 1: Circular straight sections

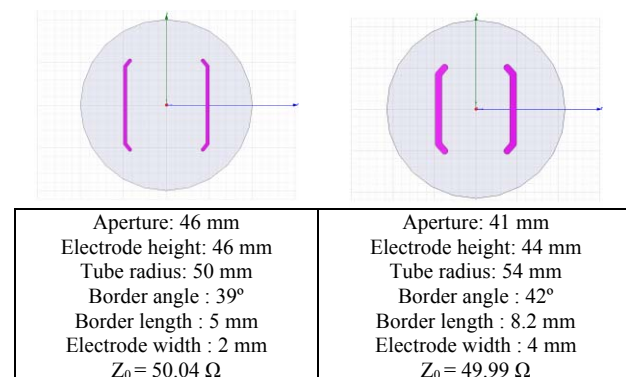

Figure 2: Planar straight sections

The fourth straight section yields the best field homogeneity due to the planar electrodes and the optimization of final edges. Also the mechanical stiffness of the electrodes is enhanced by the final edges.

\*Work supported by Spanish Ministry of Education and Science under project FPA2004-20954-E

<sup>#</sup>iker.rodriguez@ciemat.es

## ANALYTICAL CALCULATIONS

Assuming a constant force along the kicker, the increment of speed and momentum necessary to deflect a 300 MeV particle, arriving only with longitudinal speed, is given by:

$$\Delta v_{\perp} = v \cdot \tan \alpha = 2.99792 \cdot 10^8 \cdot \tan(0.008) = 2.398 \cdot 10^6 \frac{\text{m}}{\text{s}}$$

$$\Delta p_{\perp} = m \cdot \Delta v_{\perp} = (m_c + m_0) \cdot \Delta v_{\perp} = 1.282654 \cdot 10^{-21} \frac{\text{kg} \cdot \text{m}}{\text{s}}$$

The transverse voltage  $V_{\perp}$  is a characteristic magnitude of a transverse kicker that measures the normal component of the Lorentz force over the particle.  $V_{\perp}$  is defined as the integral of that force along the beam axis  $Z$ .

$$V_{\perp} = \int_0^l (\vec{E} + \vec{v} \times \vec{B})_{\perp} dz$$

That integral can only be calculated by means of numerical simulations. But the transverse voltage can also be calculated by using the relativistic momentum increment [2]:

$$V_{\perp} = \frac{\beta \cdot c \cdot \Delta p_{\perp}}{q} = 2.400044261 \cdot 10^6 \text{ V}$$

The efficiency of the kicker can be measured by the transverse shunt impedance  $R'_s$ , which relates the transverse voltage (strength) with the input power  $P$ . The definition for sinusoidal excitation is:

$$R'_s = \frac{V_{\perp}^2}{2 \cdot P}$$

As the input power is not yet known, a definition for a strip-line transverse kicker powered in differential mode can be used [2], based on geometrical parameters:

$$R'_s = 2 \cdot Z_c \cdot \left( \frac{\tanh[\pi \cdot \omega / (2 \cdot h)]}{k \cdot h} \right)^2 \cdot \sin^2(k \cdot l) \quad (1)$$

where  $k = \omega / c$ ,  $h$  is the half aperture and  $l$  is the electrode length. For the selected straight section,  $h$  is 0.0205 m and the electrode length is 1.7 m.

The transverse shunt impedance variation with frequency is depicted in figure 3. First zeroes of  $R'_s$  appear at 88.17 MHz and at 176.35 MHz. Those points will be repeated periodically each 88.17 MHz (roughly  $c/2l$ ) and will show the possible resonant frequencies of the device.

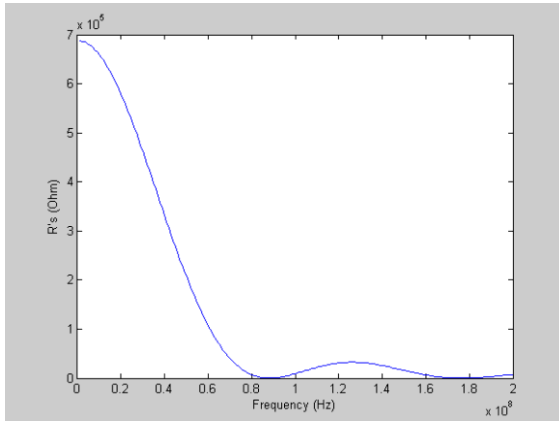

Figure 3: Transverse shunt impedance

Taking into account that the pulse flat-top length is 200 ns and the kicker electrodes are 1.7 m long, the calculations should be done as for a DC pulse. From Eq. 1:

$$R'_{sDC} = \lim_{f \rightarrow 0} (R'_s) = 2 \cdot Z_c \cdot \left( \frac{l}{h} \right)^2 = 687686 \Omega$$

Therefore, input power DC pulse excitation for 2 electrodes should be calculated as:

$$P_{DC} = \frac{V_{\perp}^2}{R'_{sDC}} = \frac{(2.400044261 \cdot 10^6)^2}{687686} = 8.37627 \text{ MW}$$

This value is, consequently, one half for one electrode:  $P_{1DC} = 4.188135 \text{ MW}$ . With this power, it is possible to calculate the pulse voltage necessary for one electrode and the peak current that appears on each strip-line:

$$V_{kDC} = \sqrt{P_{1DC} \cdot Z_c} = 14471 \text{ V} \quad I_{kDC} = \frac{V_{kDC}}{Z_c} = 289.42 \text{ A}$$

If the maximum repetition rate is 50 Hz, the averaged time power demanded from the power supply is:

$$P_{avg} = \text{Duty} \cdot P_{peak} = \frac{200}{20 \cdot 10^6} \cdot 8.376 \cdot 10^6 = 83.7 \text{ W}$$

## NUMERICAL SIMULATIONS

### Field homogeneity

For field homogeneity calculations, a fine 2D meshed sheet has been used in HFSS, although Ansys and Superfish 2D straight sections have also been modelled and simulated using an electrostatics solver for cross-checking. The homogeneity does not depend on the input power, as the problem is linear. For the circular straight section, the calculated homogeneity is  $\pm 15\%$  within a 15mm radius, far away from the specifications. The planar electrodes straight section (with square aperture) calculated homogeneity is  $\pm 3\%$ . Finally, rectangular aperture has fulfilled the specifications with homogeneity of  $\pm 0.74\%$ .

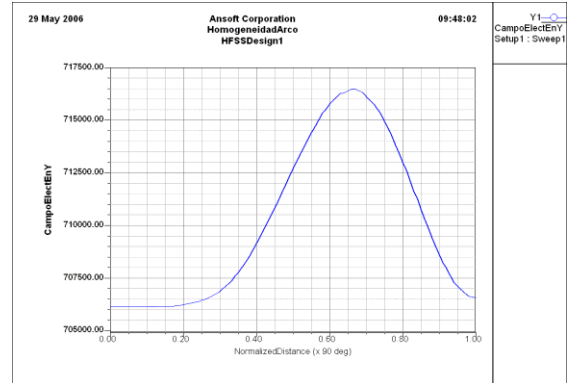

Figure 4: Transverse E field in a 15 mm arc quadrant

### Full field solution

For the analysis of high order modes and the longitudinal impedance, a full 3D kicker model has been developed in HFSS (see fig. 5). This model has been simulated at 2.5 MHz, which is the main harmonic of a typical 200 ns flat pulse with 70 ns rise/fall time, so a full field solution is available.

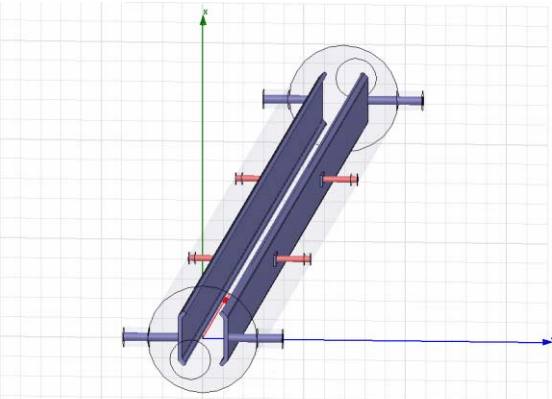

Figure 5: HFSS 3D kicker model (rectangular aperture)

Calculation of the 3D homogeneity is done for the integrated electric field  $E_y$  along the kicker. The obtained value is  $\pm 0.69\%$  for the rectangular aperture straight section. The electric field map in the middle plane of the kicker is shown in figure 6.

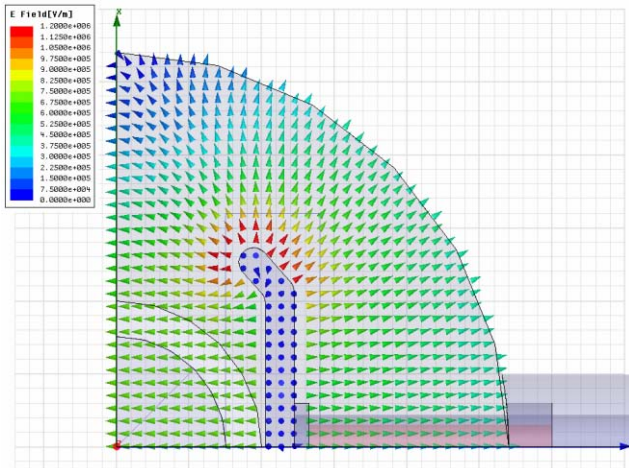

Figure 6: Electric field in rectangular aperture kicker

Electrodes voltage and current, besides the transverse voltage, have been numerically calculated [1] and they perfectly agree with the analytical results:

$$V = \int_0^l \vec{E} \cdot d\vec{l} = 14513 \text{ V} \quad I = \oint_c \vec{H} \cdot d\vec{l} = 290.4 \text{ A}$$

$$V_{\perp} = \int_0^l (\vec{E} + \vec{v} \times \vec{B})_{\perp} dz = 2418789 \text{ V}$$

Figure 7 shows the electric field  $E_y$  distribution shifting X and Z coordinates (plane  $Y=0$ ). The top is very flat.

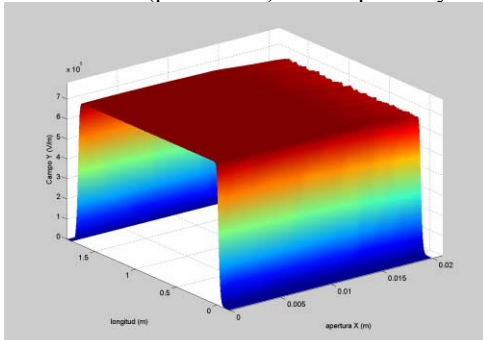

Figure 7: Electric field distribution in plane  $Y=0$

## Scattering parameters

Figure 8 shows a frequency sweep of  $S_{11}$  parameter [3]. Its value is 0.00174 at 2.5 MHz, what means that only  $|S_{11}|^2 = 3.036 \times 10^{-4} \%$  of the input power reflects to the input port at that frequency [4]. It is worth to notice that reflection is negligible in the operating bandwidth (0 to 50 MHz), with a reflected power less than 0.03 %.

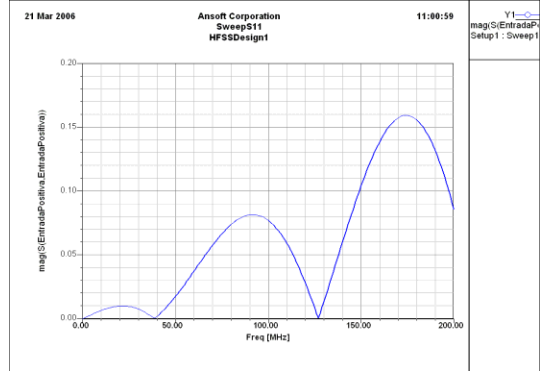

Figure 8: Reflection frequency response at inputs ( $S_{11}$ )

## FABRICATION

A first prototype of the kicker will be constructed based on this design. Concerning fabrication, several considerations have to be taken into account:

- The electrodes and the kicker tube will be made of stainless steel because of the high length of the device, so fewer stand-offs are necessary. The increment of the broadband impedance compared to aluminium is not critical. Stand-offs will be ceramic.
- The power feedthroughs and the mechanical stand-offs will slide over the electrodes to avoid thermal stress caused by differential thermal contractions. There will be only one fixed point on each electrode.
- The tapered ends will be fabricated with the higher possible length to decrease the wakefields effects.

## CONCLUSION

The technical design and analysis of the CTF3 strip-line kicker is presented. Analytical results match perfectly with numerical simulations and all the specifications are fulfilled. Longitudinal impedances, damping and HOMs in the kicker are to be presented in the near future.

## REFERENCES

- [1] ANSOFT Corporation “ANSOFT HFSS Fields Calculator Cookbook”, (2000), [www.ansoft.com](http://www.ansoft.com)
- [2] D.A. Goldberg and G.R. Lambertson, “Dynamic Devices, a Primer on Pickups and Kickers”, Lawrence Berkeley Laboratory California, American Institute of Physics (1992).
- [3] A. Gallo, A. Ghigo, F. Marcellini, M. Serio, B. Spataro, M. Zobov, “The Transverse Feedback Kicker”, DAFNE Technical Note, INFN-LNF Accelerator Division (1995).
- [4] JUAS RF Course 2006 notes. F. Caspers, T. Kroyer, February 2006.