



ATLAS TDAQ

Monitoring Questionnaire

Document Date: 20 April 2005

1 Introduction

ATLAS TDAQ project has to provide a set of tools for the online monitoring of the TDAQ system per se as well as for physics data monitoring at various points in the data flow chain. In order to achieve this goal the Monitoring Working Group (MWG) has been formed at the beginning of March in the scope of the ATLAS TDAQ project. In order to provide the monitoring system implementation in a fast and efficient way, the MWG needs a deep understanding of the online monitoring model as well as the hardware requirements for the Point 1 equipment, including the necessary network bandwidth and computing power. In order to address that issue, the current document has been prepared by the MWG. It contains a set of questions, which have been prepared in order to understand the requirements imposed on the TDAQ by detectors and offline communities. Similar attempt has been done already two years ago by the ad hoc Monitoring group[1], which prepared a questionnaire for the detectors and then produced the Monitoring requirements document[2] based on the answers to that questionnaire. Nevertheless there are two reasons for repeating this attempt: the current questionnaire has a number of additional questions, which will help us updating the requirements document and we hope that detector communities have more information available as compared with the year 2003.

The questions are grouped in several categories in order to simplify reading and answering. At the end of the document there is also an overview of the existing software tools, which have been used for the last years in the test beam and test bed activities. This may be used as a reference to the current monitoring model.

1.1 MWG scope and mandate

The Monitoring Working Group has been formed in accordance with the recommendations of the Monitoring Task Force[3], which has been working during last two months of the year 2004. The MWG includes developers of the monitoring software as well as representatives from different ATLAS sub detectors and offline communities. Detector representation is not yet complete, but this has to be worked out as soon as possible.

MWG is responsible for the development of the software tools, which can be used for the ATLAS monitoring at different phases of the project, including commissioning and physics running. In more details the following aspects of the monitoring will be covered by the software tools provided by the MWG:

- transportation of the monitoring data from the places where it is produced to the places where it will be used (analysed, stored, etc.)
- monitoring frameworks, which can be used for the analysis of monitoring data
- “smart” monitoring applications, which can be used for associating some actions with the results of monitoring process
- archiving tools for monitoring data

2 Monitoring Questionnaire

2.1 Questionnaire structure

The questionnaire is subdivided into three parts: Monitoring Data, Monitoring Results and Monitoring Storage. To some of the questions examples are given to illustrate them further as a help for the reader. For many questions a number of optional answers are proposed but other answers are very welcome as well.

2.2 Questionnaire scope

Online Monitoring refers to the process of observing some entities or processes in the experiment and sometime keeping record of them. The Monitoring as such can be used for different purposes, which may also change depending on the phase of the experiment, which may result in different requirements for the monitoring system. We assume that the usage of the monitoring software might be significantly different for the commissioning period as comparing to the physics data taking, including cosmic and normal ATLAS running. Therefore we propose to consider that each question can have two different answers, with each answer corresponding to the specific project phase.

2.3 Monitoring data

Monitoring data is an information, which is produced by an observable entity or process and can be used to acquire it's status. There are several issues related to the monitoring data, which need to be better understood.

1. At which level of the TDAQ system is your monitoring data produced? The possibilities here are: FE, ROD, LVL1, ROS, LVL2, SFI, EF.
2. What does this choice depend on:
 - availability of computing resources at a given project phase,
 - availability of the required information at a given system level,
 - something else (can you describe what)?

3. At how many places monitoring data will be produced simultaneously, i.e. how many FE, RODs, ROSES, etc. will be involved into monitoring data production at a given moment?
4. What kind of data are you going to use for monitoring: physics events (fragments), single values of basic types, arrays of values of basic types, tables, n-tuples, etc?
5. In which way are you going to monitor your system:
 - Do you want to monitor something permanently? How much data do you need to monitor (MB/hour)?
 - Alternatively how much data will you need in order to achieve your goals with monitoring? In what time do you want to acquire these data?
6. What fraction of the data, which is produced for monitoring, have to be transported over network? I.e. how many monitoring data will be internally analysed in the same node where they are produced, e.g. in the ROD crate and how many monitoring data need to be transported to remote machines for analysis, e.g. to a monitoring farm? What does this choice depends on: computing power requirements, network bandwidth requirements? For example:
 - analysis tools may be located on the ROD crate controller while the monitoring data are produced by the RODs of the same crate. In this case transportation of data does not require any kind of networking. The results of the monitoring analysis have to be transported, but this will be addressed in the following part of the questionnaire.
 - monitoring data destinations can be located on the computing nodes downstairs, while the monitoring data are produced by the ROD crate controllers (also downstairs).
 - monitoring data destinations can be located upstairs, while the monitoring data are produced by the ROD crate controllers (also downstairs).
7. Do you need a tools for configuring the monitoring process? What monitoring parameters need to be configured? For example reference histograms, types of checks, thresholds for alerts, update frequency, trigger type depended filling etc.?
8. Do you need a possibility to change the monitoring configuration on “the fly”, i.e. without restarting the processes, which are producing or processing monitoring data? For example do you want reset/rebin histograms, start/stop building histograms, etc? If yes, then how such dynamic changes should be made: manually or automatically with help of smart applications. This would be of a great interest for us if you could give here your own examples.
9. Do you need a possibility to combine monitoring information from different sources?
10. Do you need full or partial event reconstruction for the monitoring data analysis?
11. Are you going to use the offline algorithms for the monitoring data processing?
12. Are you going to correlate your monitoring data with any other online data, for example DCS data?

2.4 Monitoring Results

Monitoring results is information, which is produced by the monitoring system and does not require any further online processing. Results may be displayed, archived or be given to intelligent monitoring tools, which may automatically take some actions according to the monitoring results.

13. What kind of data will be produced as result of the monitoring process: histograms, tables, arrays, single values of basic types, arrays of values of basic types, maps, n-tuples, qualifiers (BadRun, GoodRun), etc?
14. How are you going to use results of the monitoring: look by eyes, store in the database for later usage, use it in a smart applications, which may do some actions upon those results (for example produce alarms).
15. Where are the monitoring results used: in the same node where they are produced, on arbitrary node in the TDAQ system, in control room, offline?
16. When the monitoring results are used: at the same run, at the next run, offline?
17. What is the number of sources, which produce monitoring results online?
18. What is the size of data produced by the monitoring (MB/hour)?
19. How often is it necessary to distribute those results? For example as soon as they are produced or once at the end of the run or at a regular time intervals.
20. Is it necessary to combine results produced in different places?

2.5 Monitoring Storage

21. What data has to be stored: "raw" monitoring data (histograms, graphs, arrays, blobs, etc.), monitoring results (qualifiers, constants, etc.) or both?
22. What is the size of the monitoring data, which have to be stored?
23. How often have these data be stored: once per run, periodically (what is the period)?
24. How much time these data have to be kept in the storage: days, weeks, months, always?
25. What is the required update mode for the monitoring data storage: replace the old data with the new ones, support versioning?
26. How has stored data be accessed: using simple sequential or random access, using queries: on external attributes (time, run number, version, etc.), using queries on internal attributes of the stored data (e.g. values of bins in histograms)?
27. Are there any time constraints for the access to the archived monitoring data?

3 Current status of the online monitoring software

The monitoring software, which is available for the moment can be subdivided into three categories: monitoring services, which provide a means of information sharing in the scope of distributed TDAQ system; monitoring facilities, which provide a sort of frameworks on top of these services; and graphical applications, which can be used to display monitoring data. The monitoring services have been developed and supported by the Online Software group. The monitoring facilities have been recently developed in HLT and detector communities. There are several monitoring presenter applications, which can display different types of monitoring data and have been developed in different communities.

Figures 1 and 2 shows how these monitoring software have been currently used by TDAQ system in the combined test beam 2004. In the following paragraphs different parts of the monitoring system are explained in more details.

Figure 1 Operational monitoring data flow

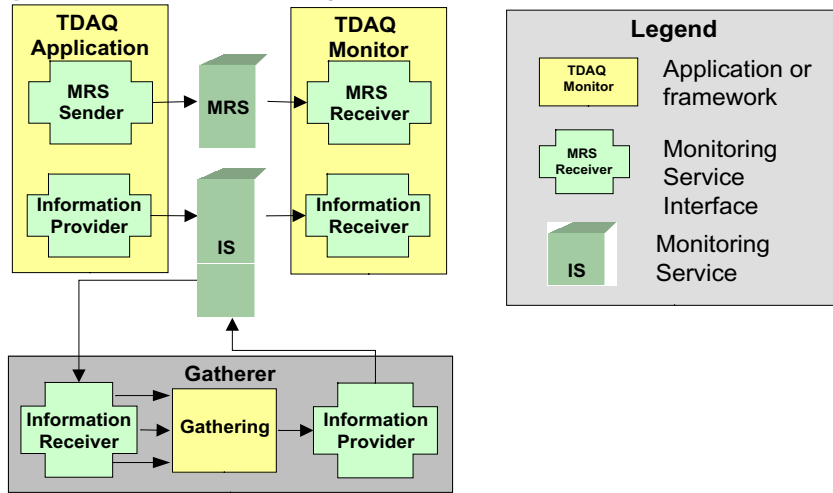
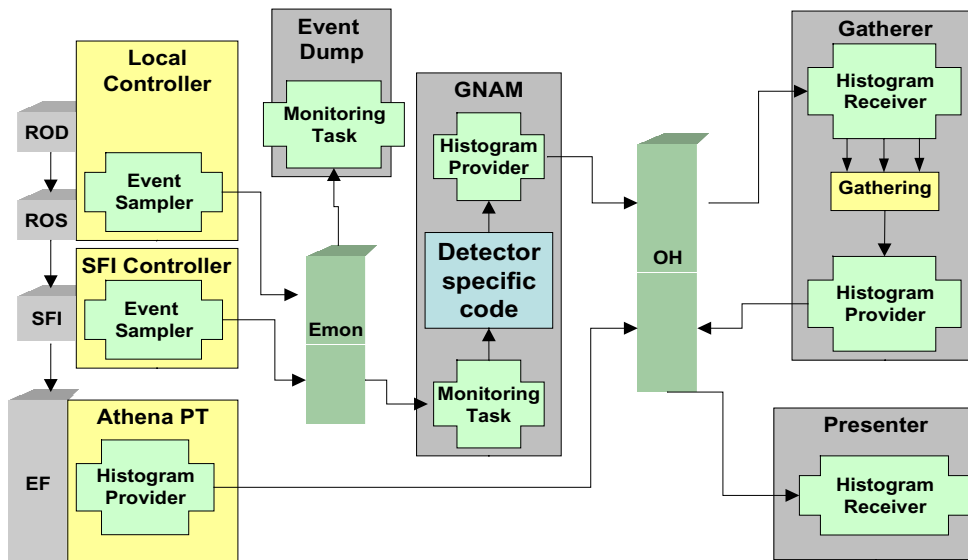

Figure 2 Physics monitoring data flow



3.1 Online Monitoring Services

The Online Software provides four services, which are intended to be used for the monitoring of the TDAQ system[4]. Namely they are: Message Reporting System (MRS)[5], Information Service (IS)[6], Online Histogramming (OH)[7] and Event Monitoring[8]. Each of these services is optimized for a certain type of monitoring data: the first three are intended to be used for the operational monitoring and the last one for the physics event monitoring.

For all of the Monitoring services the whole software development cycle has been performed, i.e. development has been preceded with the user requirements collection phase, which was followed by the design and implementation. A number of functionality, scalability and performance tests have been done for each service individually as well as in the context of the whole TDAQ system. Finally all the services have been deployed in the test beam environment.

3.2 Monitoring Facilities

There are two monitoring facilities, which have been implemented on top of the Online Monitoring services and have been successfully used during the last test beam activity. One of them is the Gatherer project[9], which is developed by the HLT community and the second one is the GNAM monitoring framework[10], which was implemented by developers from MDT detector.

The Gatherer is a software framework to collect and sum up similar monitoring information produced by distributed online processes. It makes the full statistics monitoring information available for the online presenter and/or the archiving system. It can also run user defined algorithms to analyse the monitoring information. The Gatherer uses the Information Service and the Online Histogramming service to collect/publish the monitoring information (histograms or user defined data structures in IS). The Gatherer software package is part of the HLT software release and it uses both, the Online Software and the Dataflow releases.

The GNAM facility is a software framework, which can execute user specific monitoring plugins. Each plugin must implement two interfaces provided by GNAM: one for decoding detector specific event fragments and another one for filling specific histograms. The GNAM itself takes care of bringing the necessary event fragments to the user plugins using the Event Monitoring service and for publishing the filled histograms into the Online Histogramming service.

3.3 Monitoring Presenters

There are several monitoring GUI applications, which have been developed inside the TDAQ group. They can be used to display various monitoring data, which can be obtained from one of the four Online Software monitoring services. The most widely used programs are:

- Information Service monitor – general purpose GUI application, which can be used to view the content of the Information Service. This application has been developed in the Online Software group.

- Event Dump[11] – the GUI, which can display the content of a physics event, which has been read from file or received from the Event Monitoring service. This application has been developed in the Online Software group.

There is also an application called PMPresenter[10], which has been developed recently by the Tile subdetector community and has been actively used during the last test beam. The Presenter is an interactive histogram display, which may retrieve histograms, which have been published in the Online Histogramming service and display them using ROOT.

3.4 References

- 1 Old Monitoring group home page,
<http://atlas.web.cern.ch/Atlas/GROUPS/DAQTRIG/MONITORING/monitoring.html>
- 2 Monitoring requirements document, <https://edms.cern.ch/document/393921/>
- 3 Monitoring Task Force report, <https://edms.cern.ch/document/555827/0.3>
- 4 Online Monitoring software framework in the ATLAS experiment, S.Kolos et al., Proceedings of the CHEP 2003, La Jolla, USA,
<http://cdsweb.cern.ch/search.py?recid=685522&ln=en>
- 5 Message Reporting System home page,
<http://atddoc.cern.ch/Atlas/DaqSoft/components/mrs/Welcome.html>
- 6 Information Service home page,
<http://atddoc.cern.ch/Atlas/DaqSoft/components/is/Welcome.html>
- 7 Online Histogramming home page,
<http://atlas-onlsw.web.cern.ch/Atlas-onlsw/oh/oh.htm>
- 8 Event Monitoring home page,
<http://atddoc.cern.ch/Atlas/DaqSoft/components/monitoring/Welcome.html>
- 9 Portable Gathering System for Monitoring and Online Calibration at ATLAS, Conde Muino, P. et al., Proceedings of the CHEP 2004, Interlaken,
<http://cdsweb.cern.ch/search.py?recid=797460>.
- 10 GNAM home page, <http://pfzema.cs.infn.it/pfzema/phys/GNAM/>
- 11 Event Dump home page,
<http://atddoc.cern.ch/Atlas/DaqSoft/components/evtdump/Welcome.html>