

# CLIC Accelerated R and D programme

## 1. CLIC concept

A high-energy (0.5–5 TeV centre-of-mass), high luminosity ( $10^{34} - 10^{35} \text{ cm}^{-2} \text{ s}^{-1}$ ) electron-positron Collider (CLIC) is being studied at CERN within an international collaboration of laboratories and institutes to provide the HEP community with a new accelerator-based facility for the post-LHC era, for more details see <http://preprints.cern.ch/yellowrep/2000/2000-008/p1.pdf>.

It has been optimised for 3 TeV but can be built in stages without major modifications. An overall layout of the complex is shown in Fig.1. A single tunnel, housing only the two linacs and the various beam transfer lines, results in a very simple, cost effective and easily extendable configuration for energy upgrades.

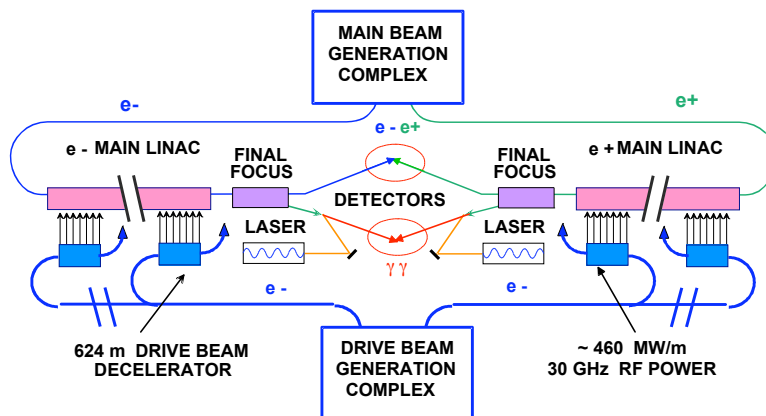

**Fig. 1: Overall layout of the CLIC complex.**

In order to achieve the design luminosity, very low emittance beams have to be produced and focused down to very small beam sizes at the interaction point ( $\sim 1\text{ nm}$  in the vertical plane). Beam acceleration using high frequency (30 GHz) normal-conducting structures operating at high accelerating fields (150 MV/m) significantly reduces the length and, in consequence, the cost of the linac. The overall-length of the 3 TeV collider is about 38 km. The pulsed RF power (460 MW per metre length of linac) to feed the accelerating structures is produced by the so-called “Two-Beam Scheme” in which the 30 GHz power is extracted from high-intensity/low-energy drive beams running parallel to the main beam. These drive beams are generated in a centrally-located area and then distributed along the main linac. The beams are accelerated using a low frequency (937 MHz) fully-loaded normal-conducting linac. Operating the linac in the fully-loaded condition results in a very high RF-power-to-beam efficiency ( $\sim 97\%$ ). Funnelling techniques in combiner rings are then used to give the beams the desired bunch structure with the concomitant increase in intensity, in this process the bunch spacing is reduced in stages from 64 cm to 2 cm, and the beam current is increased from 7.5 to 240 A.

***It is generally accepted that CLIC technology is the only viable technology for multi-TeV colliders.***

## **2. Main differences with other more conventional design studies**

- The CLIC accelerating gradient of 150 MV/m is very ambitious, and results in a total linac length of 27.5 km for a 3 TeV collider, or 4.8 km for a 0.5 TeV collider. The highest gradient proposed by the other studies is 50 MV/m, or a two-linac length of 13.8 km for a 0.5 TeV collider.
- CLIC technology enables the energy reach of a future linear collider to be extended possibly even up to 5 TeV, other design proposals have maximum energies of about 1 TeV.
- The CLIC design is based on the “two-beam scheme” for power production, the other “normal-conducting” studies use conventional schemes which power the main linac directly using several thousands of klystrons and pulse compression systems (more than 8000 klystrons are required for a 1 TeV collider).
- The CLIC rf frequency of 30 GHz is approximately three times higher than that proposed for the other “normal-conducting” schemes.

## **3. Advantages of the CLIC scheme**

- The fact that there are no active rf components in the main linac means that CLIC can use a single small-diameter tunnel – linacs which are powered directly with klystrons need either a large diameter tunnel or a second service tunnel to accommodate the rf power sources.
- A particularly attractive feature of the CLIC scheme is that to upgrade the energy of the collider, the only change in the rf power system required is a change in the pulse length of the modulators which drive the low frequency (937 MHz) klystrons and not an increase in the number of klystrons (the nominal pulse length for the 3 TeV collider is 100 microsec).
- Only a relatively small number of klystrons are required for the CLIC scheme – this is independent of the final energy. The power for each drive-beam accelerator is supplied by 200 50 MW multi-beam klystrons which are grouped together in the central area of the facility. This central location facilitates power distribution, cooling and maintenance work.
- The energy required for acceleration is transported, compressed and distributed using high power electron beams – conventional systems generate the rf power locally and then transport it over long lossy waveguides – the CLIC energy is only converted into rf power where it is required (typically 60 cm from each CLIC main linac accelerating structure).
- The use of a high rf frequency reduces the peak power that is required to achieve the 150 MV/m accelerating gradient.

#### **4. Disadvantages of the CLIC scheme**

- There is a fixed investment cost for the drive beam generation system of the CLIC two-beam scheme which is independent of energy. This makes the scheme less cost effective at low energies but this disadvantage disappears at high energies.
- The fact that CLIC is not powered by small modular sub-units makes the demonstration of technical feasibility more difficult.
- Conditioning of the drive and main linacs with rf power is more complicated for a two-beam scheme than for a conventional scheme with conventional rf power sources.
- The higher CLIC rf frequency makes the scheme more sensitive to alignment errors and ground stability.

#### **5. Summary of what has been achieved**

- Basic designs of all CLIC sub-systems and essential equipment have been made but more design work is required. Details of the work already accomplished is summarised in 590 CLIC Notes and other publications, for more details see <http://ps-div.web.cern.ch/ps-div/CLIC/Publications/CLICNotes.html>
- The technical feasibility of two-beam acceleration has been demonstrated in CLIC Test Facility 2 (CTF2). In this test, the energy of a single electron bunch was increased by 60 MeV using a string of 30 GHz accelerating cavities powered by a high intensity drive linac.
- Peak accelerating gradients of 190 MV/m have been obtained in CTF2 using molybdenum-irises in 30 GHz copper structures with rf pulse lengths of 16 ns. This result has to be confirmed for the nominal CLIC pulse length (130 ns).
- An experimental demonstration of the principle of the bunch combination scheme has been made at low charge using a modified layout of the former LEP Pre-Injector (LPI) complex.
- A successful demonstration of full-beam-loading operation has been made using the injector of the new CLIC Test Facility 3 (CTF3).
- A prototype CLIC quadrupole has been stabilized to the 0.5 nm level in a relatively noisy part of the CERN site using commercially available state-of-the-art stabilization equipment. Sub-nm stability is required to collide nm-size beams.
- The active pre-alignment system has been tested in CTF2 and held components in place during normal operation of the two-beam test accelerator within a window of  $\pm 2$ -3 microns. This meets the present CLIC requirement.

## 6. What remains to be demonstrated

- There are two categories of feasibility issues that remain to be demonstrated.
  - (i) CLIC-technology-related feasibility issues
  - (ii) Issues common to other linear collider studies
- *The new CLIC Test Facility CTF3 is being built to demonstrate all the key CLIC-technology-related issues of the CLIC two-beam scheme.*
- Issues common to other linear collider studies will be studied within the framework of the existing world-wide linear collider collaborations, and in particular in Europe, within the EU FP6 Programme.

## 7. CLIC-technology-related feasibility issues

The International Technical Review Committee has indicated a number of crucial items for which the CLIC Collaboration has still to provide a feasibility proof (the so-called R1 items) and also a number of issues, which must be investigated in order to arrive at a Conceptual Design (R2 items).

It is proposed to focus attention initially on the "CLIC-Technology-Related" issues as opposed to issues which are common to all linear collider studies. Adopting this approach, there are three R1 key feasibility issues and two R2 issues, which have to be demonstrated first before any further work can be envisaged.

*The three R1 issues are:*

*R1.1 Test of damped accelerating structure at design gradient and pulse length*

*R1.2 Validation of the drive beam generation scheme with a fully loaded linac*

*R1.3 Design and test of an adequately damped power-extraction structure, which can be switched ON and OFF*

*The two R2 issues are:*

*R2.1 Validation of beam stability and losses in the drive beam decelerator, and design of a machine protection system*

*R2.2 Test of a relevant linac sub-unit with beam*

All the five above-listed key R1 and R2 feasibility issues can be demonstrated by CTF3.

## 8. CTF3 Test Locations

Fig.2 shows the locations in the CTF3 facility where each of the key feasibility tests will be performed.

The test of a damped accelerating structure at the design gradient and pulse length (R1.1) requires the linac-driven high-gradient test stand to be completed (location 1)

The validation of the drive-beam generation scheme with a fully-loaded linac (R1.2), and the design and test of an adequately damped power-extraction structure, which can be switched ON and OFF (R1.3), requires the complex to be completed up to and including the combiner ring (location 2)

The validation of beam stability and losses in the drive-beam decelerator, and design of a machine protection system (R2.1), and the test of a relevant linac sub-unit with beam (R2.2), requires the CTF3 experimental area CLEX, which consists of a high-power test stand (location 3), the Test Beam Line (TBL) (location 4) and the probe beam with a relevant linac two-beam module (location 5)

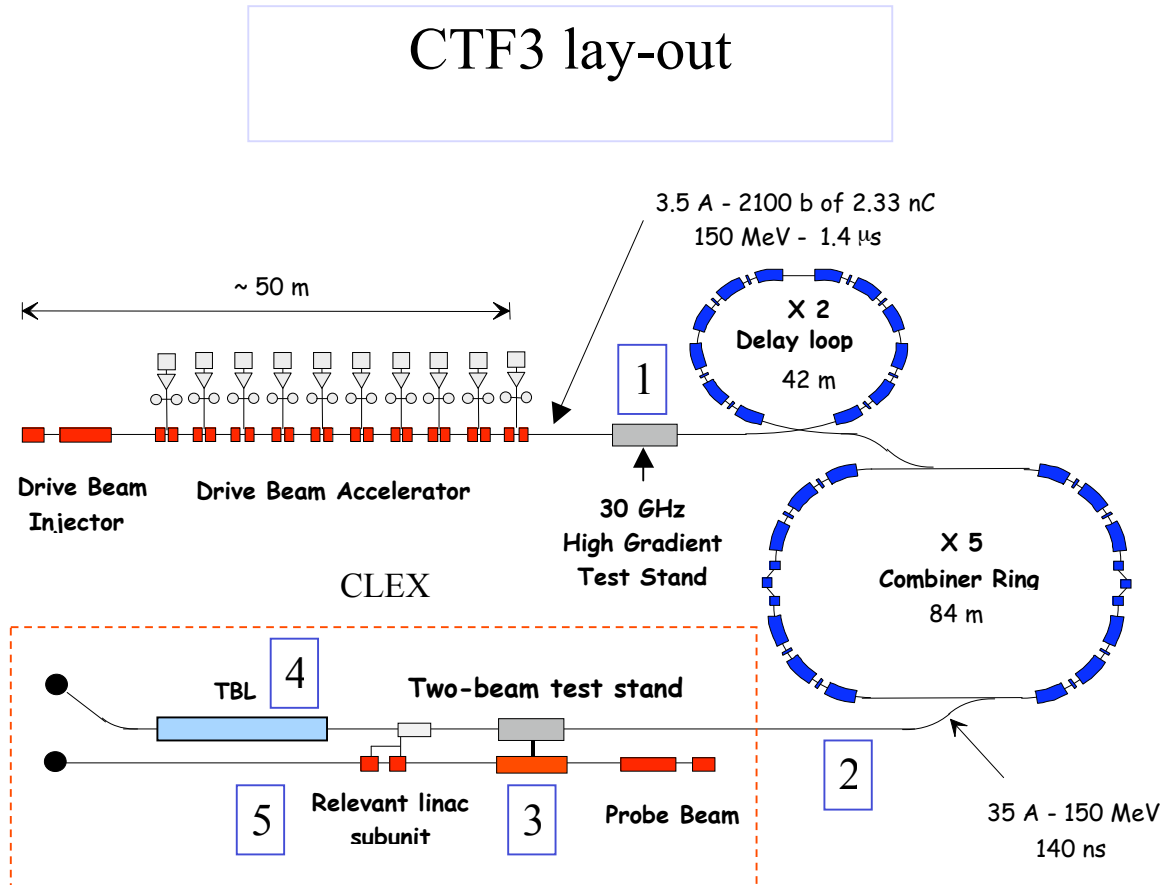

**Fig. 2 Schematic layout of the CLIC Test Facility CTF3**

(the numbered boxes show the location in the facility where the five key feasibility tests will be performed)

## 9. Presently funded and unfunded sub-systems

In CERN's Medium and Long Term Plans, the CLIC study is funded at the level of 3.4 MCHF/y and 27 man-years/y, from which 2.6 MCHF/y and 23 man-years/y are devoted to CTF3. With the resources available from CERN and the one provided by the existing collaborations with INFN, LAL, NW University of Illinois, RAL, SLAC,

and Uppsala University, the linac and the delay loop will be completed by the end of 2005. Assuming the CERN funding rate continues until 2009, the following extra resources (with respect to the present level of funding) would be necessary to complete the above-mentioned feasibility programme.

- 5.7 MCHF and 14 my for the combiner ring
- 8.5 MCHF and 38 my for CLEX including (i) power test stand (ii) representative linac two-beam module (iii) main-beam linac and (iv) Test Beam Line (TBL).
- 2 MCHF and 6 my to instrument and automate the linac-driven high-gradient test stand
- 0.5 MCHF and 12 my for structure technology developments
- 0.5 MCHF and 25 my for the maintenance and full-time operation of CTF3

**A total of 17.2 MCHF and 95 man-years to demonstrate the critical R1 and R2 issues before 2010. The associated spending and manpower profiles are given in Fig. 3 and Fig. 4.**

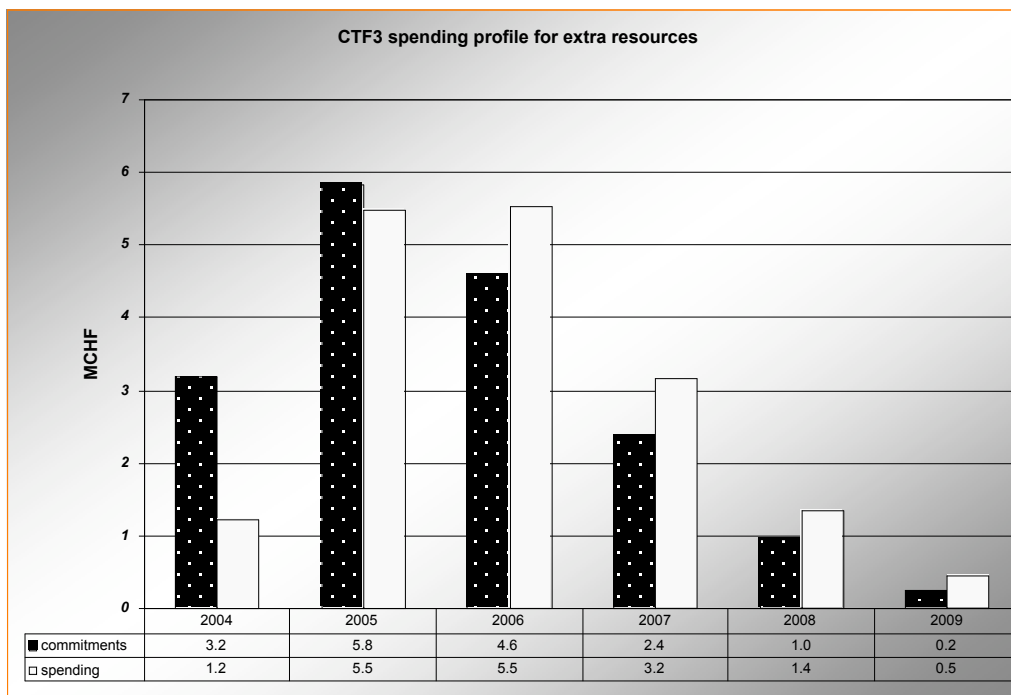

**Fig. 3 Spending profile for extra resources**

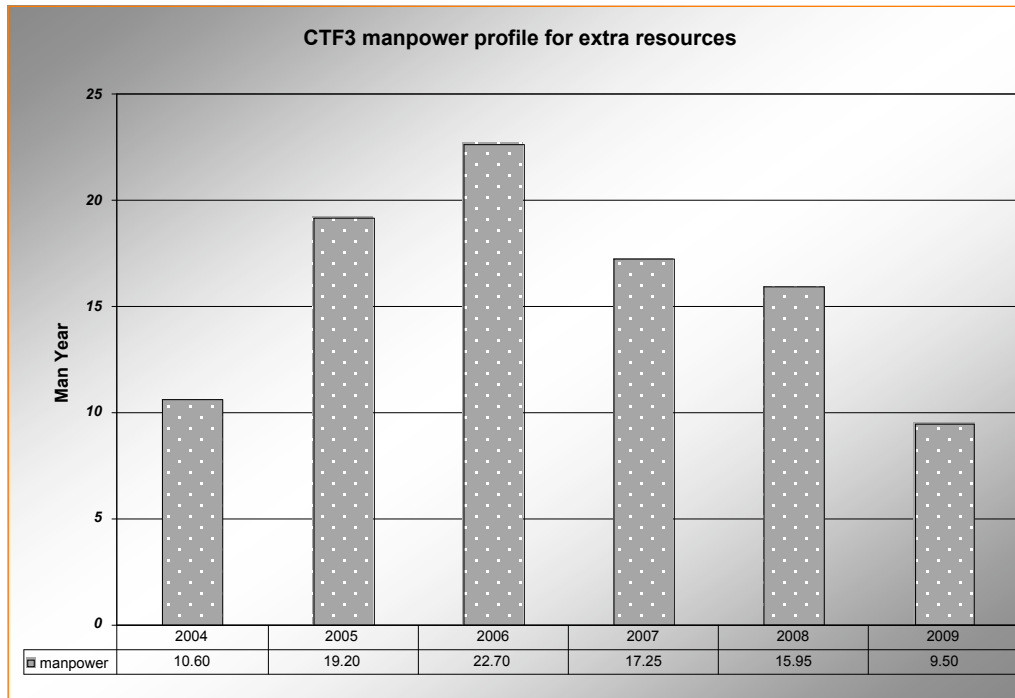

**Fig. 4 Manpower profile for extra resources**

## 10. Planning

The important construction and installation phases together with the test periods of the key feasibility issues are given in Fig.5.

|  | 2004 | 2005 | 2006 | 2007 | 2008 | 2009 |
|--|------|------|------|------|------|------|
| Drive Beam Accelerator                                       | █    |      |      |      |      |      |
| 30 GHz high-gradient test stand                              | █    | █    |      |      |      |      |
| 30 GHz high-gradient testing (4 months per year)             |      | █    |      |      |      |      |
| <b>R1.1 feasibility test of CLIC accelerating structure</b>  |      |      |      | ▨    |      |      |
| Delay Loop   | █    | █    |      |      |      |      |
| Combiner Ring  | █    |      | █    |      |      |      |
| <b>R1.2 feasibility test of drive beam generation</b>        |      |      |      | ▨    |      |      |
| CLEX   |      | █    | █    |      |      |      |
| <b>R1.3 feasibility test of PETS* structure</b>              |      |      |      | ▨    |      |      |
| Probe Beam   |      |      | █    | █    |      |      |
| <b>R2.2 feasibility test of relevant CLIC linac sub unit</b> |      |      |      |      | ▨    |      |
| Test beam line   |      | █    | █    | █    | █    |      |
| <b>R2.1 Beam stability bench mark tests</b>                  |      |      |      |      | ▨    | ▨    |

**Fig. 5 Important CTF3 milestones.**

\* 30 GHz Power Extraction and Transfer Structure (PETS)

## **11. Stand-alone high-power 30 GHz test stand**

Although this item is not included in the request for extra resources, it would be highly desirable to have a stand-alone high-power 30 GHz source (in parallel with, but independent of CTF3) to carry out the high-gradient testing. The time required to condition structures is difficult to estimate with the present state of knowledge but recent data suggests that molybdenum structures require significantly more time than copper structures. If this proves to be correct the number of CTF3 operating hours foreseen for conditioning structures will have to be significantly increased which will put too heavy a burden on an already ambitious CTF3 test program. In this case, it will be indispensable to have a stand-alone high-power 30 GHz source (independent of CTF3) to carry out the high-gradient testing. It should be noted that if CLIC moves on to the design stage several of these high-power 30 GHz sources will be needed to validate all the critical RF components. Such devices are not off-the-shelf items and would need some development by industry or an outside institute.

## **12. Work packages**

All the activities, including those covered by the present resources, and the activities not yet funded, which are required for the above-mentioned feasibility programme, is presented in the form of work packages in Annex 1. The required resources (material and manpower) which are not presently available in the CERN MTP (unless specifically mentioned), are indicated together with the time schedule. Member State Institutions are invited to contribute to this programme by providing voluntary contributions “à la carte”, in cash, in kind and/or in manpower, including full technical responsibility for part, complete or several work packages. Note that in a few cases, where indicated, the nature of the work is such that the work has to be carried out by CERN. Although the resources required to complete work packages 7.1, 2.3 and part of 7.2 are covered by the CERN MTP programme, collaborations with other institutes are sought to expedite the work and/or to introduce innovative ideas.



### Annex 1: CTF3 accelerated programme– work packages

For more detailed specifications of the equipment please refer to the CTF3 design report <http://doc.cern.ch/archive/electronic/cern/preprints/ps/ps-2002-008.pdf>  
Whenever possible CTF3 makes use of equipment built for the former LEP Pre-Injector (LPI) - therefore for some of the items mentioned below some material already exists. This is mentioned in the work packages concerned.

| <i>Work Package</i>  | <i>Provider</i>                                       | <i>Schedule</i>   | <i>Resources</i>                         |
|--|---|---|--|
| <b>1. Combiner Ring (CR), Transfer Line (TL1) to CR and Transfer Line (TL2) with bunch compressor to CLIC EXperimental Area (CLEX)</b>   | Collaborating institute or CERN                       | Up and including CR:<br>ready for installation end 2005,<br>TL2: 2006 | <b>Total WP1<br/>5.7 MCHF<br/>14 m*y</b> |
| 1.1 Optics layout<br>A reference layout exists from INFN, further optimisation and follow-up in conjunction with final integration is necessary.   | INFN (LNF)  |   | 1 m*y                                    |
| 1.2 Magnets<br>Design and procurement of all magnets for the Combiner Ring the transfer lines and the bunch compressor.<br>These include bending magnets, quadrupoles, sextupoles, path length wigglers, septa and corrector magnets. For most magnets a design is already available                                     | Collaborating institute or CERN                       |   | 1.85 MCHF<br>4 m*y                       |
| 1.3 Vacuum system<br>Design and procurement of the aluminium vacuum chambers for the 80 m circumference ring and transfer lines, vacuum pumps, pumping ports, vacuum gauges, shielded bellows.<br>A large part of the design of equipment made by INFN for the Delay Loop can be used. Detailed design work is required. | INFN(LNF)   |   | 0.7 MCHF<br>2 m*y                        |
| 1.4 Beam diagnostic equipment<br>Supply of 32 beam position monitors, and vacuum ports for synchrotron light. Such monitors have already been developed for the CTF3 Delay Loop. This design could be used without modification  | Collaborating institute or CERN                       |   | 0.53 MCHF<br>1 m*y                       |
| 1.5 Power converters for all magnets<br>Some power supplies are available from LPI.  | CERN  |   | 1.16 MCHF<br>1.8 m*y                     |
| 1.6 Technical services and installation<br>cabling, water-cooling, alignment, air conditioning   | CERN  |   | 1.05 MCHF<br>2 m*y                       |
| 1.7 Control system for combiner ring and related software<br>The system has to be compatible with the existing controls infrastructure   | CERN, possibly in collaboration with external experts |   | 0.1 MCHF<br>1 m*y                        |

|  |  |   |  |
|--|--|---|--|
| 1.8 Fast kicker with High Voltage pulser<br>Design and manufacture of the fast kicker system (kicker and high voltage pulser) for the Combiner ring<br>Special attention has to be given to the impedance seen by the beam.  | Collaborating institute or CERN            |   | 0.24 MCHF<br>1 m*y                       |
| 1.9 RF distribution system for RF deflector<br>Fabrication and installation of the complete waveguide system from the klystron to the RF deflector in the Combiner Ring  | CERN                                       |   | 0.1 MCHF<br>0.2 m*y                      |
| <b>2. 30 GHz RF power test stands</b>  |  |   | <b>Total WP2<br/>2.9 MCHF<br/>10 m*y</b> |
| 2.1 Automated 30 GHz high gradient test stand<br>Design, procurement, installation and participation in exploitation of all equipment required for the 30 GHz test stand. This includes all RF and diagnostic equipment as well as the software for automatically operating this installation. Such a test stand will be installed during 2005 in CTF3. This work package includes participation in structure testing. | Collaborating institute or CERN            | Start in 2004, to be implemented in stages from 2005 to 2007                | 2 MCHF<br>6 m*y                          |
| 2.2 Two-Beam test stand in CLEX<br>Design, construction and installation of 30 GHz RF test stand for test of PETS and two-beam operation. This test stand can be built in conjunction with WP 2.   | Collaborating institute or CERN            | Design, fabrication: 2005/2006<br>Operational 2007, together with 4 in 2008 | 0.9 MCHF<br>4 m*y                        |
| 2.3 30 GHz RF pulse compression system<br>Pulse compression system (delay line or similar device) to compress the long-pulse 30 GHz power pulses obtained from the linac-driven PETS into short high-power pulses for the test stand for CLIC component testing  | Development by collaborating institute     | 2005  | CERN MTP                                 |
| <b>3. Design and construction of the CLEX building</b>   | CERN                                       | Construction during 2006  | <b>1 MCHF<br/>2 m*y</b>                  |
| <b>4. 200 MeV Probe beam linac</b><br>Design, procurement installation and exploitation of the probe beam linac – including :<br>Electron gun, acceleration system, optics, magnetic and diagnostic elements, vacuum system.<br>The following equipment from the former LEP injector linac (LIL) are available :<br>klystron / modulator, RF distribution (3 GHz), and 3 GHz accelerating structures.                  | Collaborating institute or CERN            | Manufacture 2006/2007<br>Operational 2008                                   | <b>1.6 MCHF<br/>9 m*y</b>                |
| <b>5. Relevant CLIC linac sub unit with beam</b><br>Construction and test with beam of one PETS structure with two CLIC accelerating structures  | CERN in collaboration with other institute | Manufacture 2007<br>Operational 2008  | <b>1.5 MCHF<br/>8 m*y</b>                |

|   |   |  |                                       |
|---|---|--|---------------------------------------|
| <p><b>6. 35 A Test Beam Line (TBL)</b><br/> Design, construction, installation, exploitation and bench-marking simulation tests of a 20 m long, well-instrumented test decelerator with typically 10-15 RF power-extracting structures (PETS), to validate the CLIC drive beam stability and losses with the CTF3 beam. The making of the PETS for the TBL is part of WP 7.</p> | <p>CERN in collaboration with other institute</p> | <p>Design 2005/2006, ready for tests in 2008</p> | <p><b>1 MCHF</b><br/><b>8 m*y</b></p> |
|---|---|--|---------------------------------------|

|   |   |   |  |
|---|---|---|--|
| <b>7. 30 GHz structure development</b>  | Collaborating institute or CERN   | ongoing 2004 – 2009   | <b>Total WP7<br/>3.0 MCHF<br/>19 m*y</b> |
| 7.1 Accelerating structure development:<br>Addresses all conceptual, design, and some fabrication issues for accelerating structures. Most of this work is covered in the CERN medium term plan (MTP).  | Collaborating institute or CERN   | ongoing 2004 – 2009   | CERN<br>MTP                              |
| 7.2 PETS development:<br>Addresses all conceptual, design, and some fabrication issues for PETS structures (covered by MTP).<br><br>Fabrication of 12 PETS for TBL in CLEX.   | Collaborating institute or CERN   | ongoing, proof-of-principle prototype for 2007<br>TBL PETS - 2008 | 2.5 MCHF<br>7 m*y                        |
| 7.3 Structure technology development:<br>Addresses technological and fabrication issues for accelerating and PETS structure developments (refractory metals, copper alloys, composites, 5-axis machining and metrology). The TS department at CERN would be the most appropriate place to do this work if the necessary resources can be found.                                   | Collaborating institute or CERN   | 2004-2006   | 0.5 MCHF<br>12 m*y                       |
| <b>8. Operation of CTF3</b><br>Support for operating the facility. This essentially concerns development of operation software .  | CERN, in collaboration with other institutes  | up to 2010  | <b>0.5 MCHF<br/>25 m*y</b>               |
| <i>The following item is not part of this request for extra resources, but is considered to be highly desirable (see chapter 12).</i>   |   |   |  |
| <b>9. 30 GHz stand-alone power source for development of CLIC RF equipment:</b><br>Design, development, installation and commissioning at CERN of a 200 MW RF power source at 30 GHz, pulse length 140 ns, repetition frequency 50 Hz.<br>Candidates are gyrokystron, FEM, magnicon or similar devices. Several of these devices might be combined to achieve the required power. | Development by collaborating institute or order from industry with experience with similar devices. | Delivery mid 2006, ready for operation at CERN beg. 2007          | <b>10 MCHF<br/>6 m*y</b>                 |

