

EUROPEAN ORGANIZATION FOR NUCLEAR RESEARCH

DIRAC Note 08-02
22 February 2008

**Test with a laser
of C₄F₁₀ Cherenkov detectors**

V. Brekhovskikh, A. Kuptsov, J. Martincik, T. Trojek

GENEVA
2008

1 C_4F_{10} Cherenkov detectors

In 2006 two C_4F_{10} detectors detectors (fig. 1) were manufactured for particle identification in the DIRAC experiment. Each detector has 4 spherical mirrors, 4 flat mirrors and 4 photomultipliers (fig. 2). Cherenkov light for $\beta = 1$ is shown in fig. 3.

In the boxes of the detectors the spherical and flat mirrors were installed. For test with a laser instead of photomultipliers the half transparent screens with grids were used (figs. 4 and 5). The screen position is coincides with the photocatode position. The detectors were kept in the frames for transportation. The frames allowed to keep the detectors in horizontal position and to overturn the detectors.

2 Light from the laser, calculation

Laser light imitates the kaon beam from πK atoms (fig. 6). Vertical divergency of the kaon beam is $\pm 1^\circ$ starting from the target. Coordinates of the sources of positive and negative kaons relative to the magnet centre are $x = -206$ mm, $y = \pm 86$ mm. Angles of the kaon beams relative to the secondary beam axis are $\pm 7.7^\circ$. Horizontal divergency of the kaon beams is $\pm 2.7^\circ$ (angular aperture is 5.4°). Distance from the kaon beam sources to the entrance window of the detector is 4379 mm.

Calculated laser light for the left top mirror and PM from the kaon like sources in the magnet is in figs. 7, 8, 9, 10, 11 and 12. Calculated laser spots on the screen (photocatode) are in fig. 13. Photocatode diameter is 120 mm.

3 Light from the laser, measurements

The laser was positioned in accordance with figs. 9 and 11. To direct laser light precisely a front grid was fixed on the entrance window of the counter.

Calculated and measured laser spots on the four photocatodes of the first (left arm) detector are in figs. 14, 15, 16 and 17, for the second (right arm) detector are in figs. 18, 19, 20 and 21. Difference between positions of calculated and measured laser spots is a few millimeters.

4 Laser light imitating Cherenkov light

The angle of Cherenkov light from relativistic electrons in C_4F_{10} gas is 3.03° . To imitate Cherenkov light the laser was displaced in the transverse direction by the distance corresponding to 3.03° and the laser light was directed to the same points on the front grid as it was before displacement. Results are in fig. 22. Diameter of Cherenkov ring from fig. 22 is about 65 mm.

5 Laser light from the magnet centre

The laser was displaced in the transverse direction by 86 mm. Laser spots on the right bottom PM photocatode (first detector) are in fig. 23. Displacement is about 15 mm. Kaons from the magnet centre are really absent.

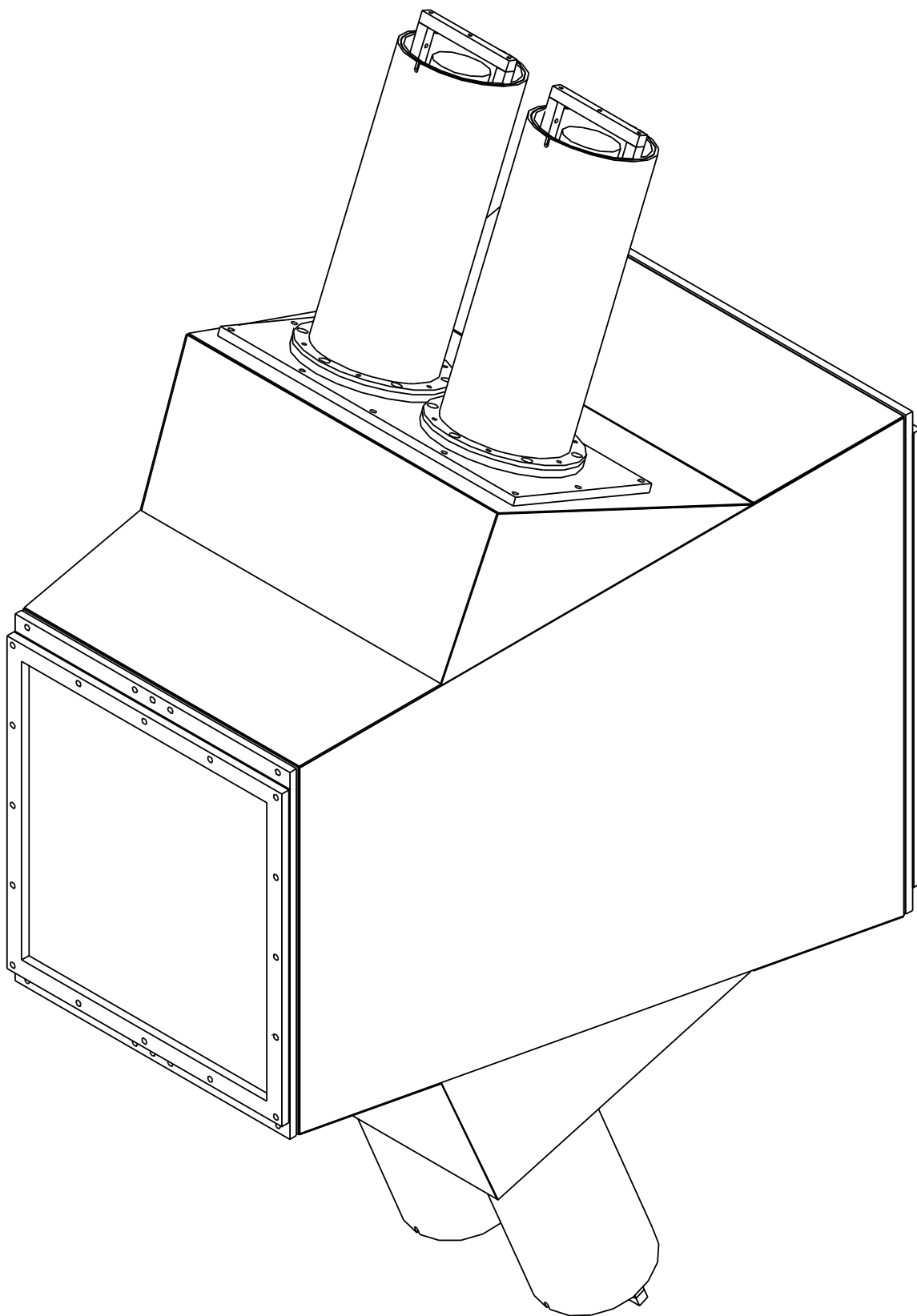

Figure 1: C_4F_{10} detector.

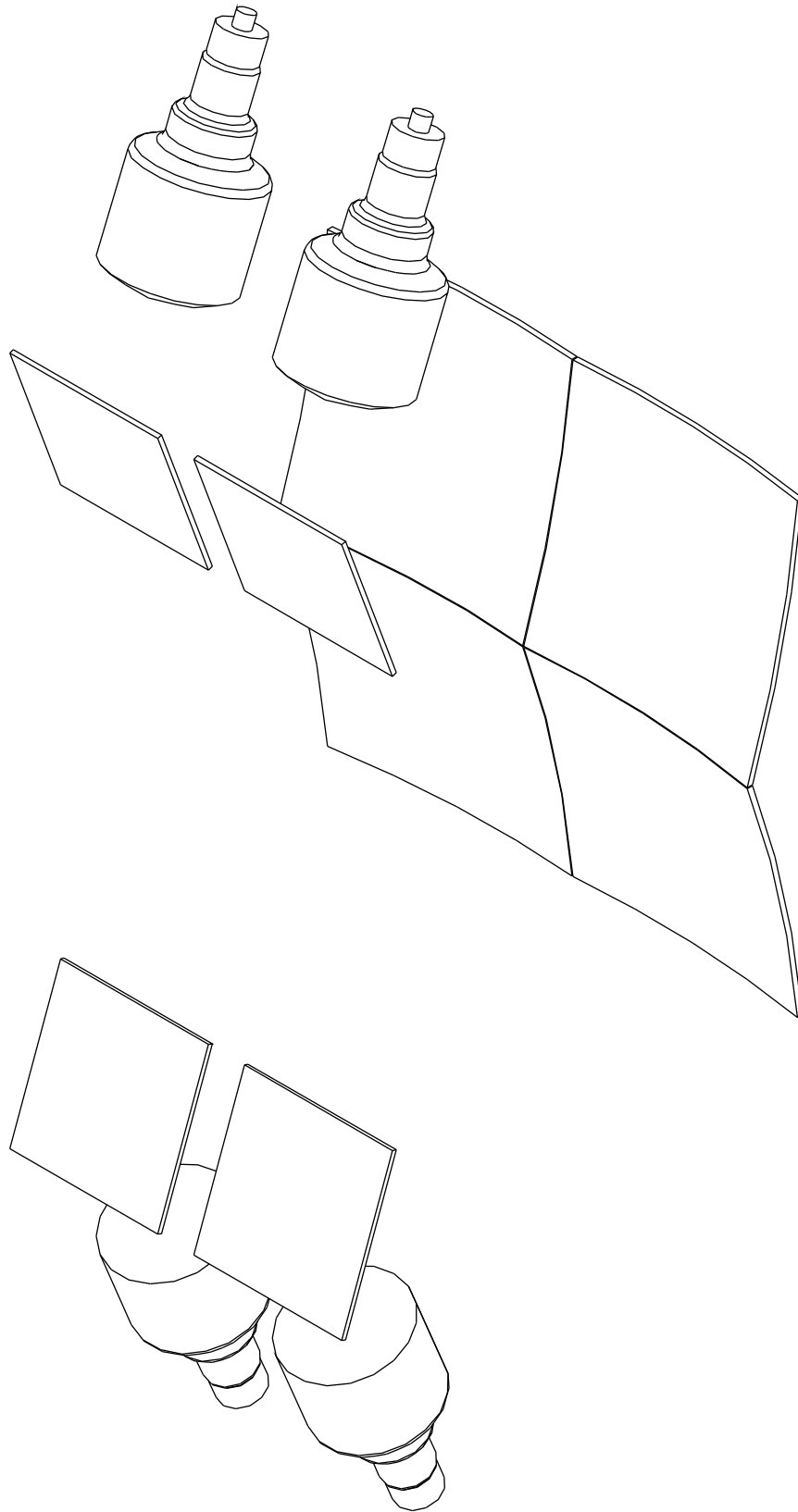

Figure 2: *Spherical and flat mirrors with PMs in the C_4F_{10} detector.*

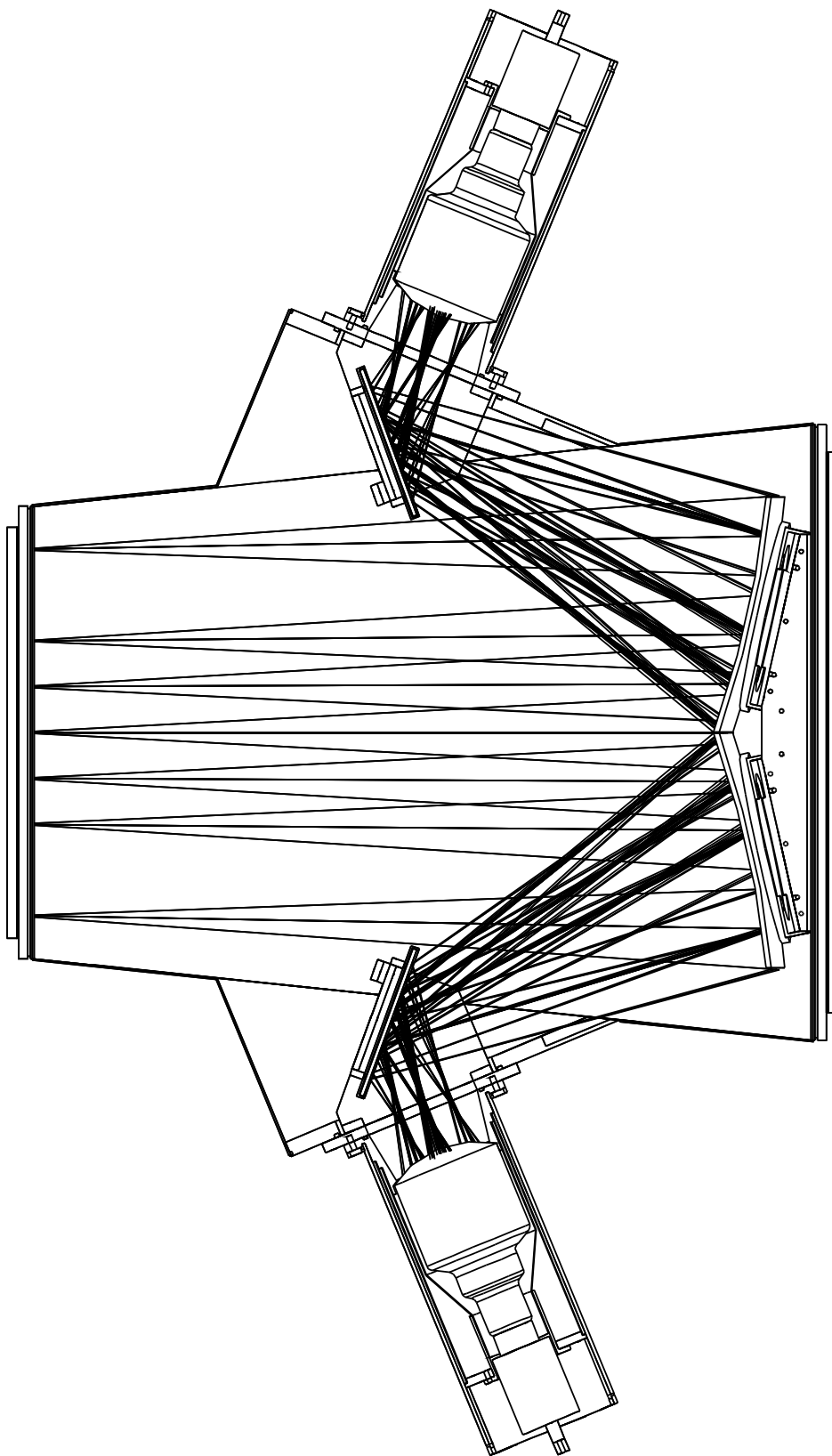

Figure 3: *Cherenkov light for $\beta = 1$ in C_4F_{10} detector.*

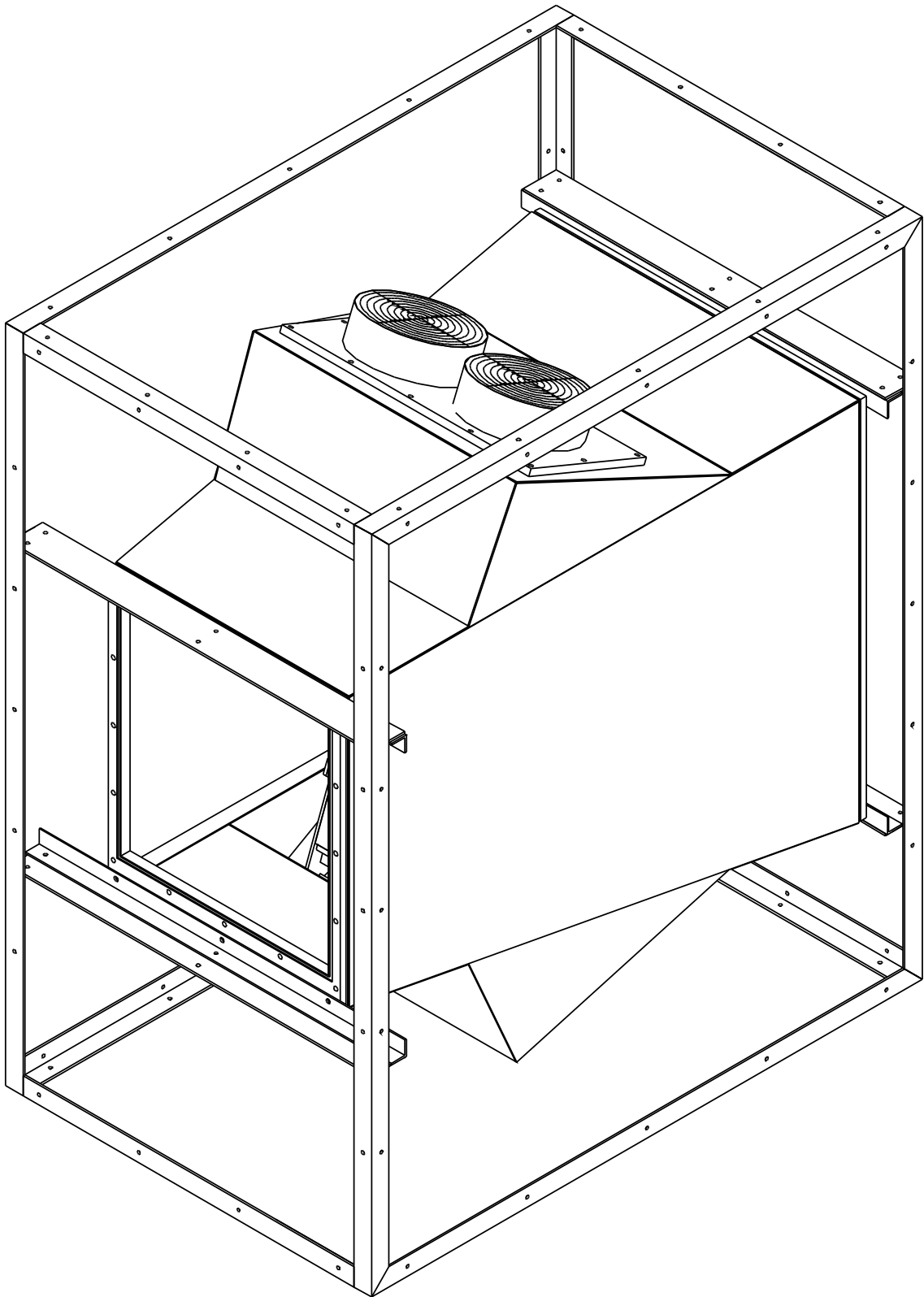

Figure 4: C_4F_{10} detector prepared for test with laser.

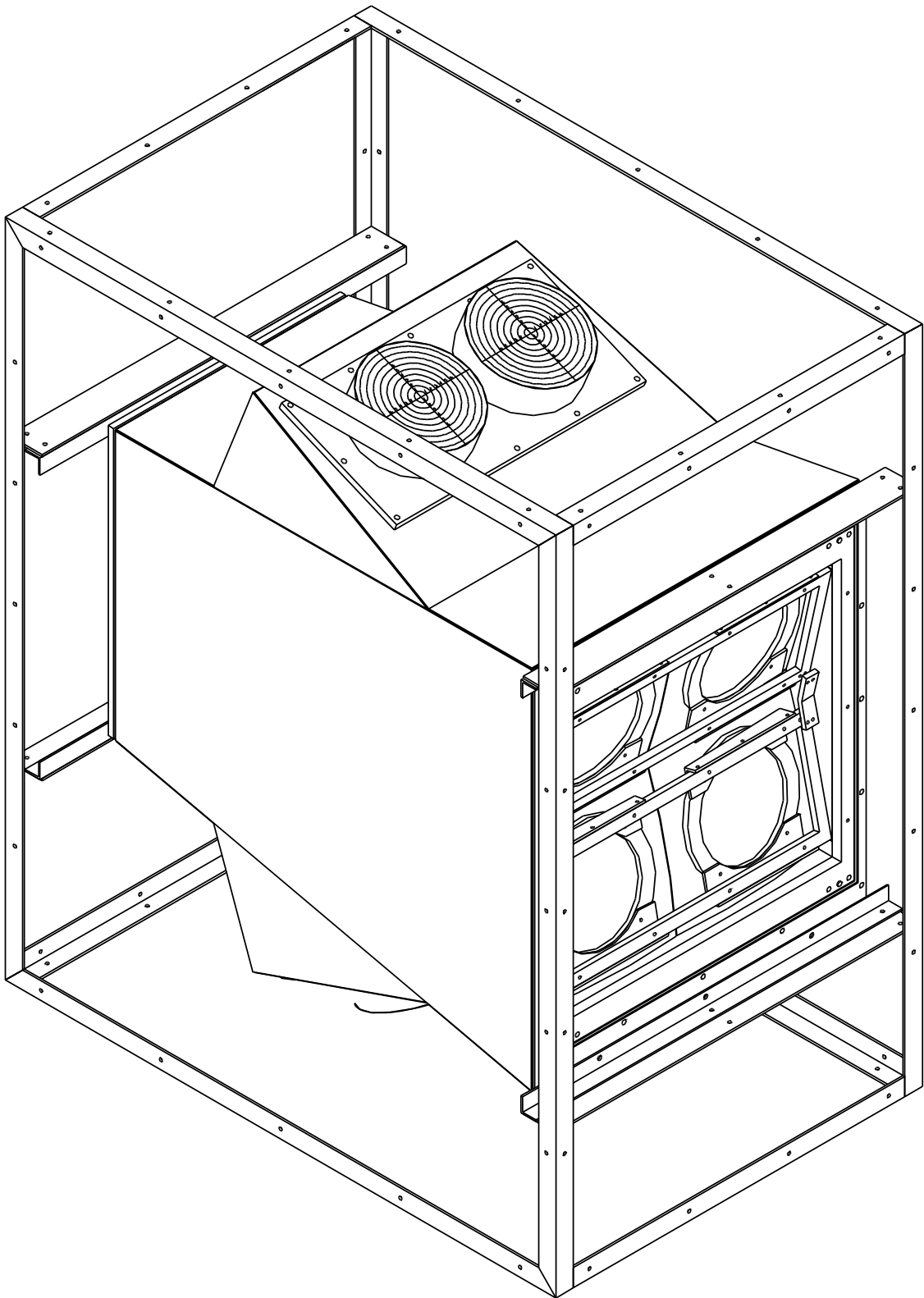

Figure 5: C_4F_{10} detector prepared for test with laser.

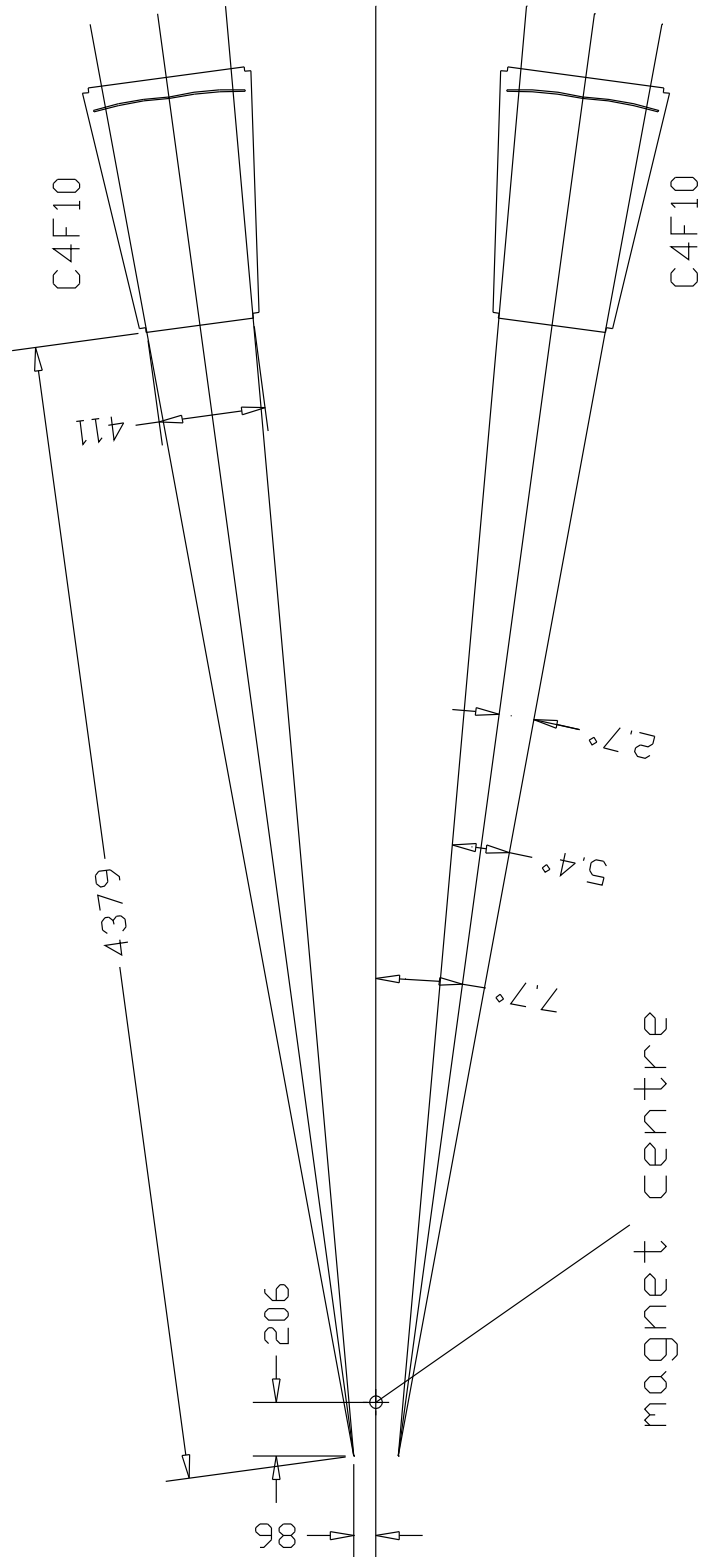

Figure 6: C_4F_{10} detectors and positive (left) and negative (right) kaon beams (from simulation). Coordinates of kaon sources are $x = -206$ mm, $y = \pm 86$ mm. Coordinates of the magnet centre are $x = 0$ mm, $y = 0$ mm. Angles of the kaon beams are $\pm 7.7^\circ$, angular aperture is 5.4° . Distance from the kaon beam sources to the entrance windows of the detectors is 4379 mm.

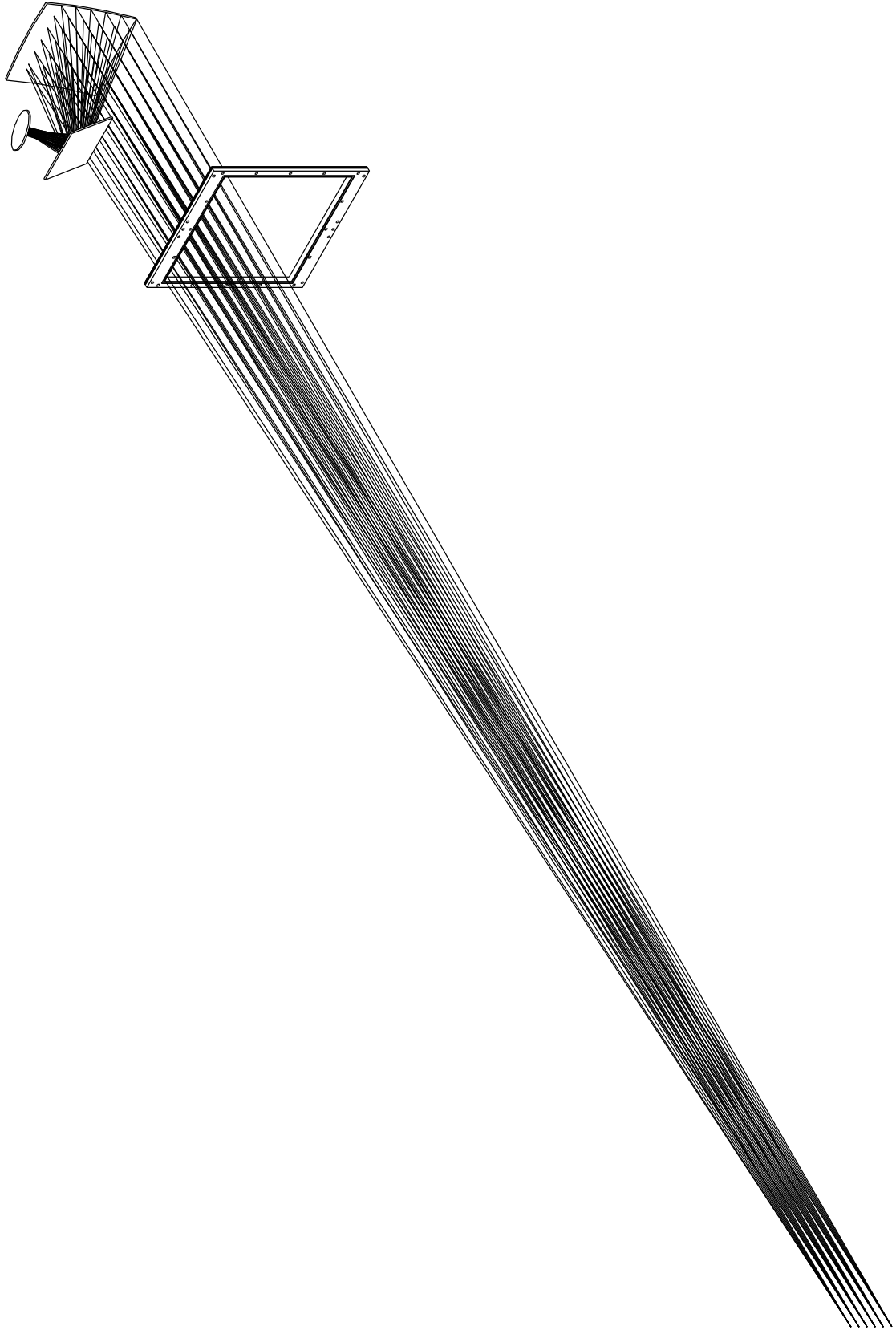

Figure 7: *Laser light from kaon like sources, front frame of the detector, top left mirror and PM photocatode. Isometrical view.*

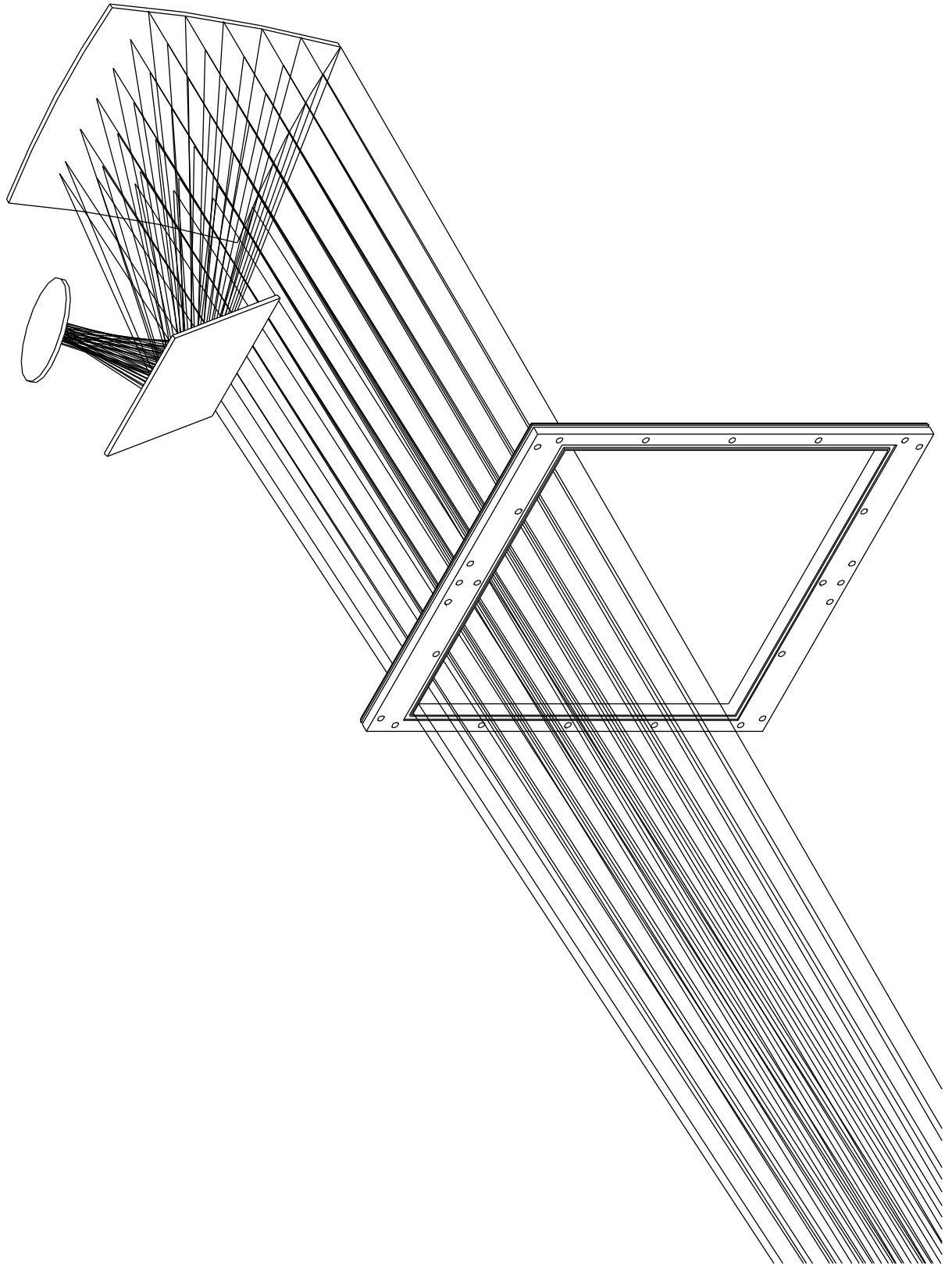

Figure 8: *Laser light from kaon like sources, front frame of the detector, top left mirror and PM phototode. Isometrical view.*

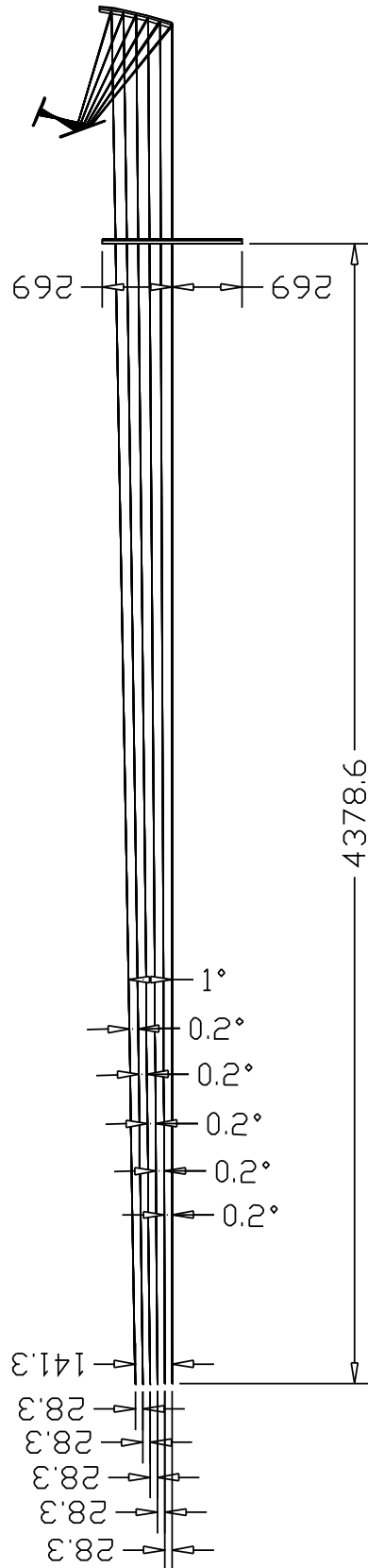

Figure 9: *Laser light from kaon like sources, front frame of the detector, top left mirror and PM photocatode. Side view.*

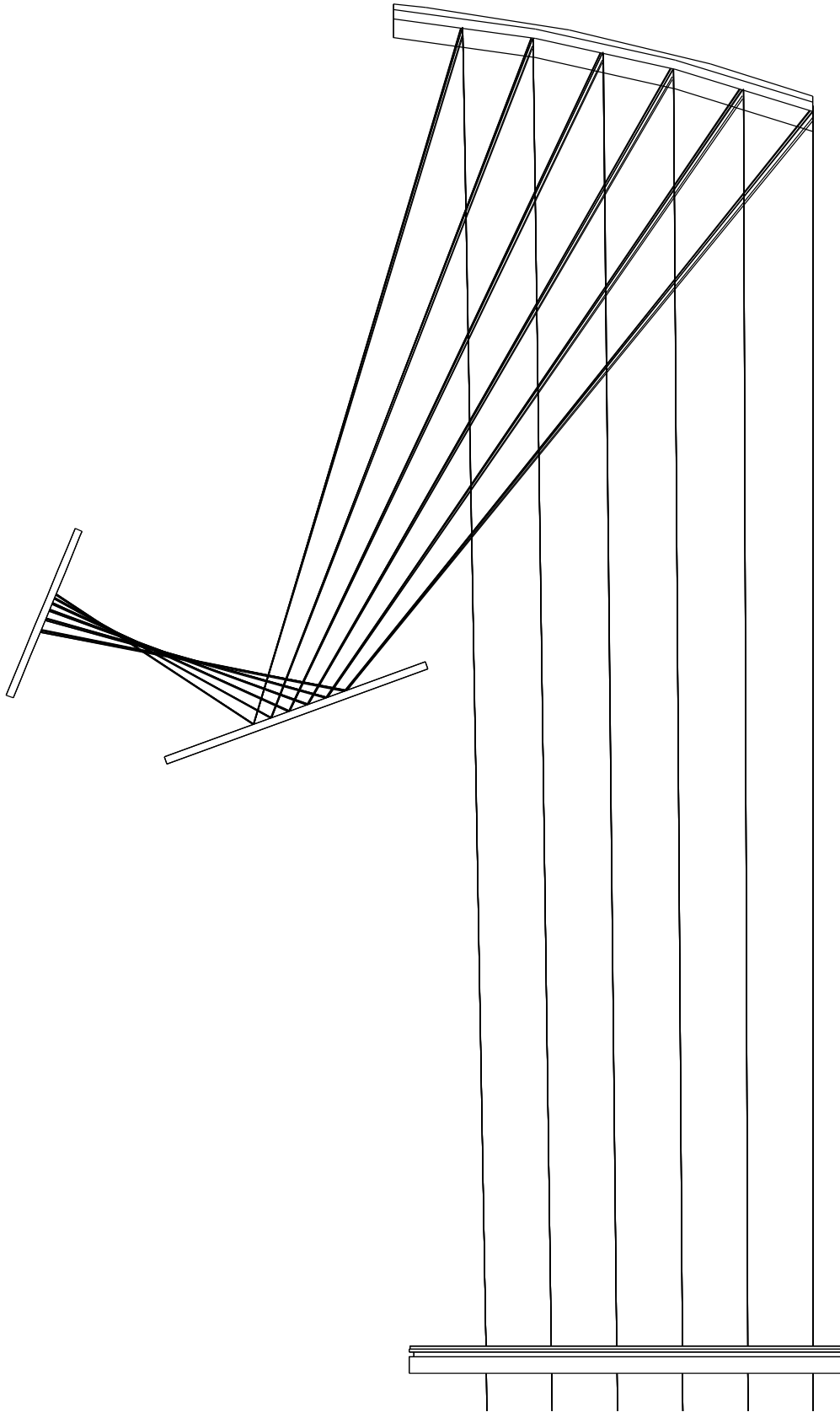

Figure 10: *Laser light from kaon like sources, front frame of the detector, top left mirror and PM photocatode. Side view.*

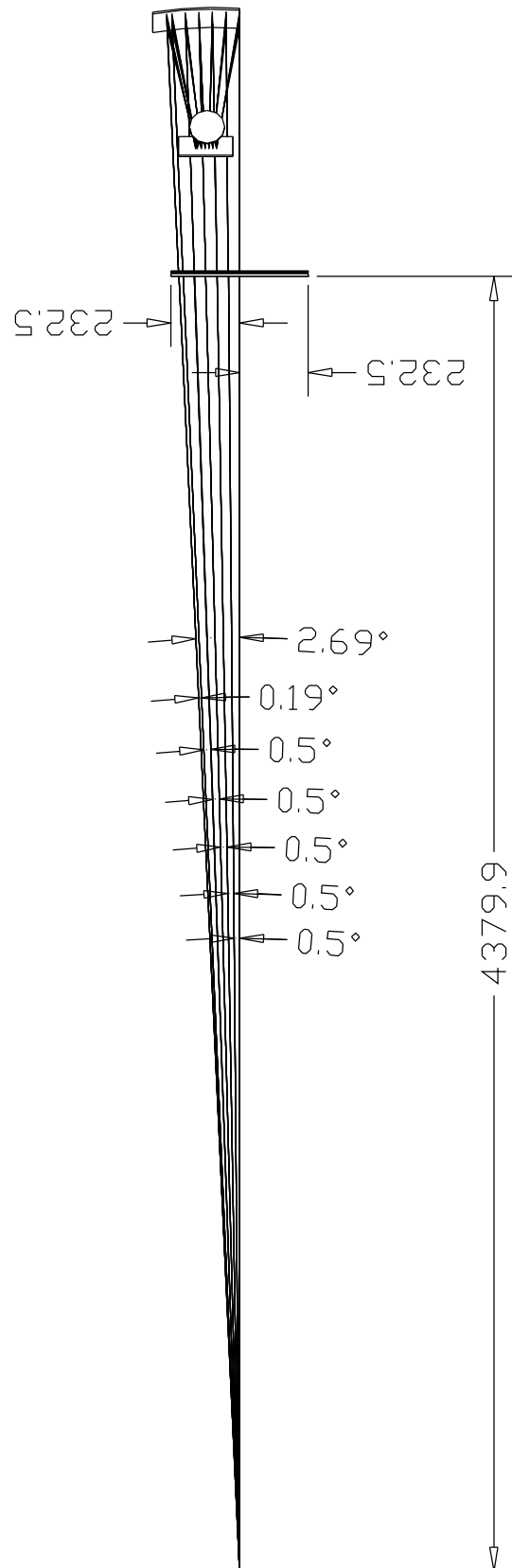

Figure 11: *Laser light from kaon like sources, front frame of the detector, top left mirror and PM photocatode. Top view.*

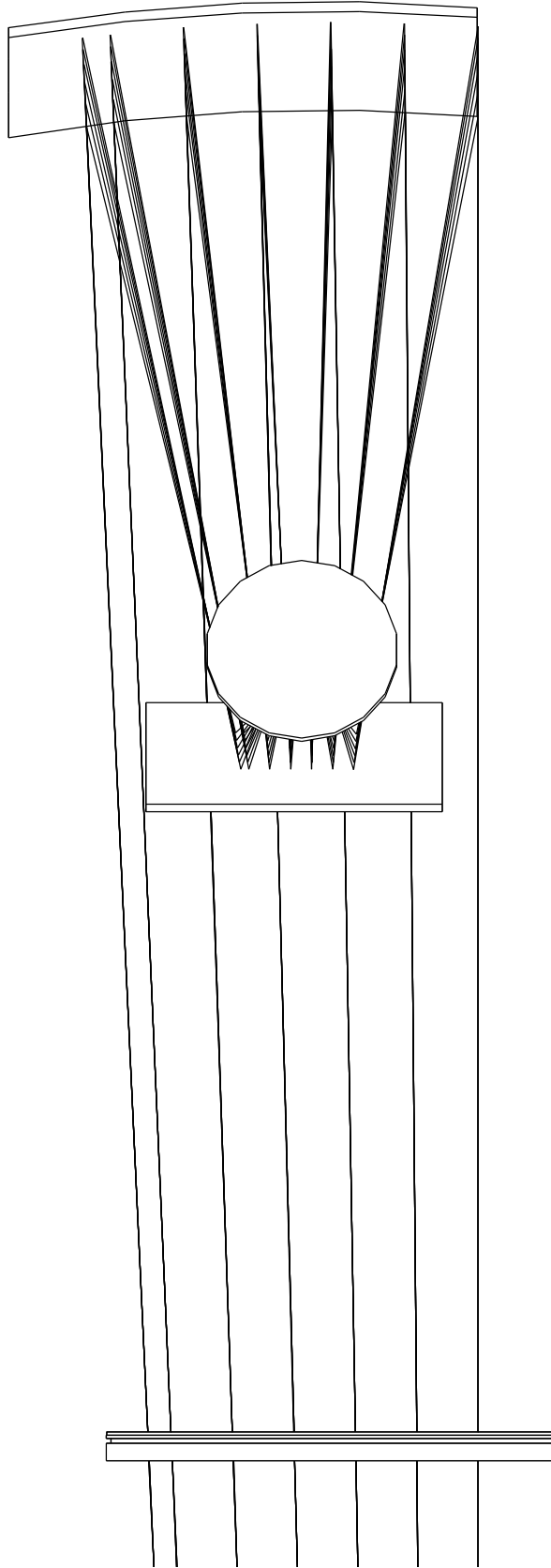

Figure 12: *Laser light from kaon like sources, front frame of the detector, top left mirror and PM photocatode. Top view.*

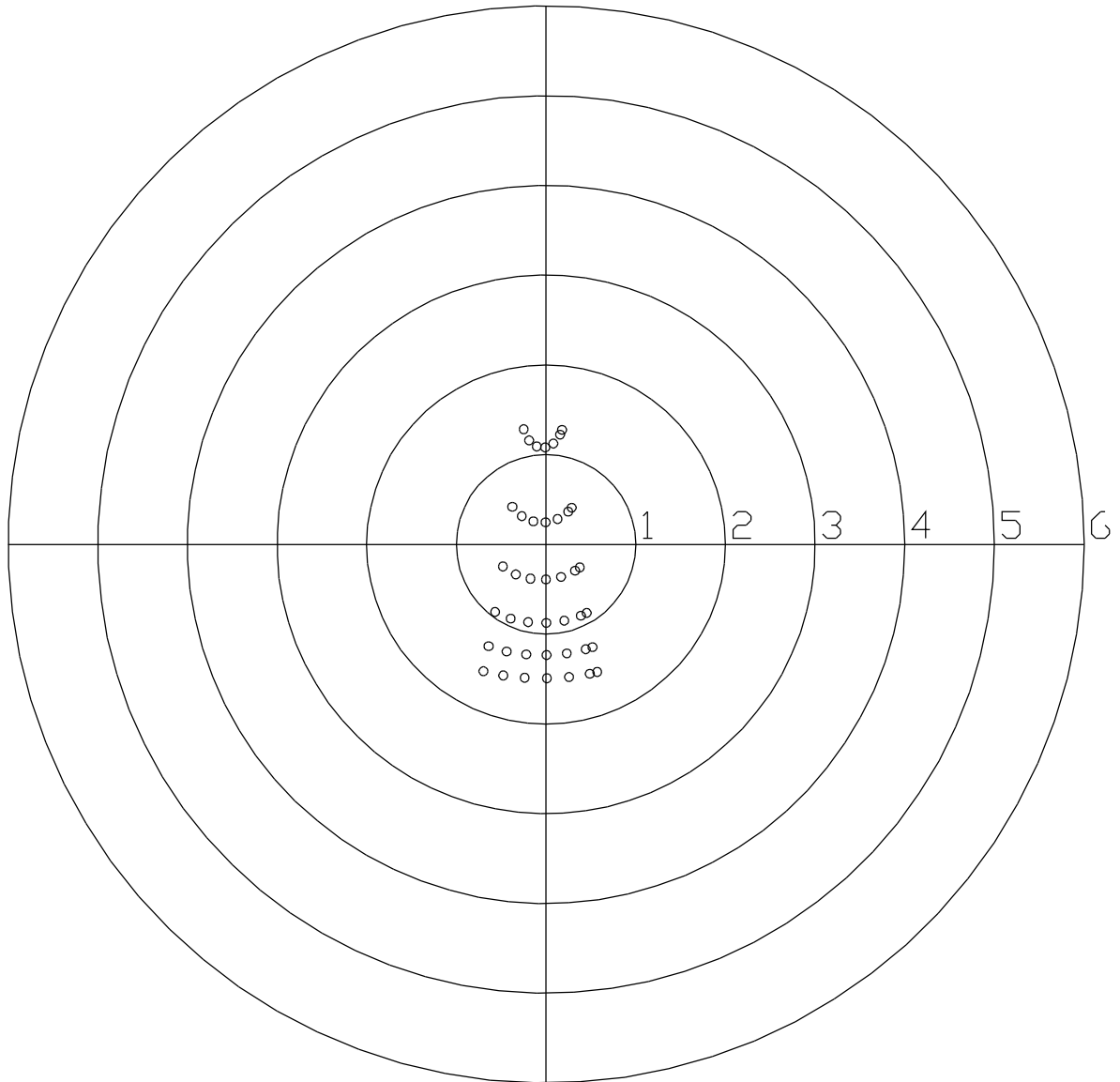

Figure 13: *Calculated laser spots on the PM photocatode. Scale in cm.*

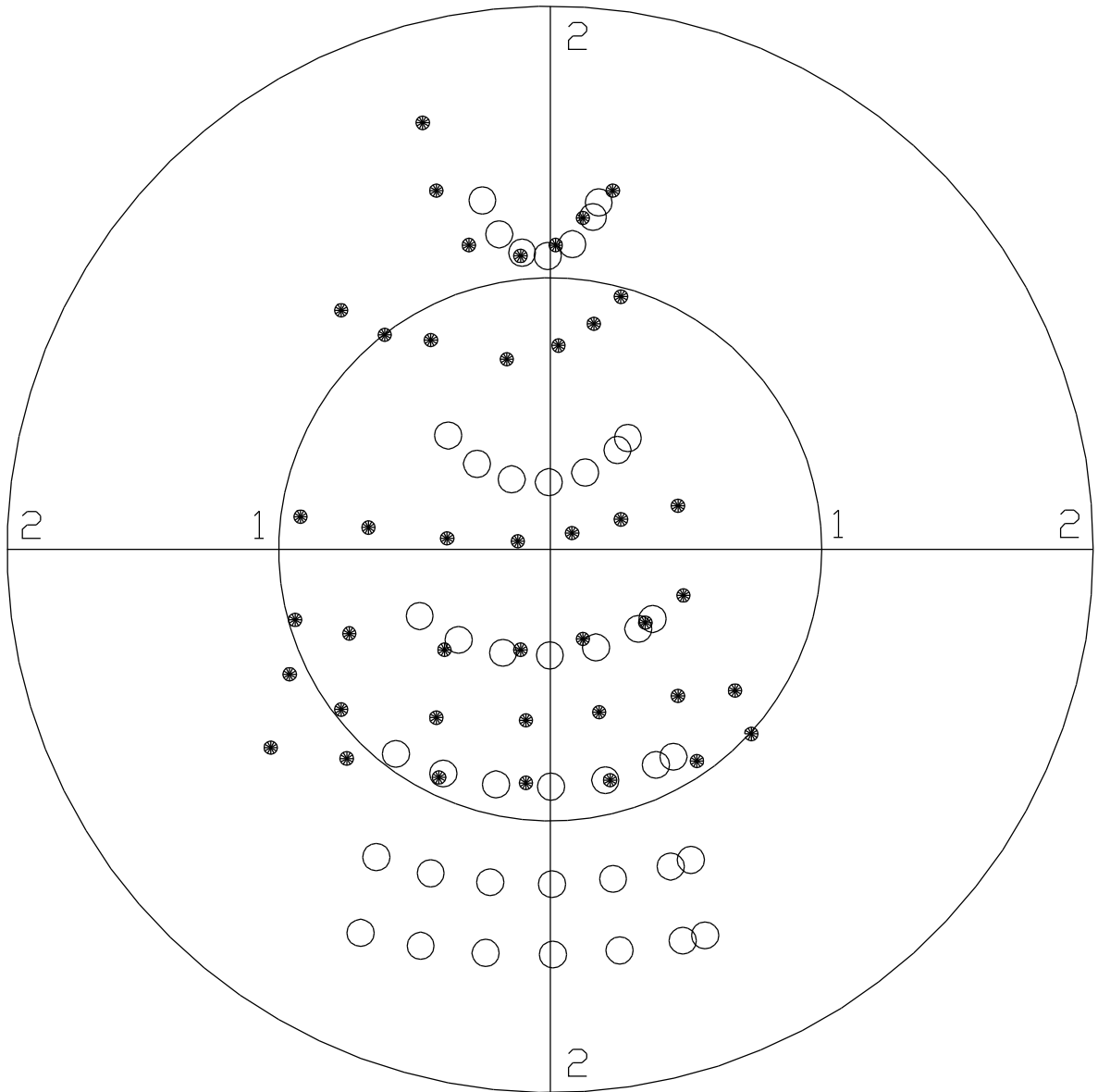

Figure 14: *Laser spots on the left top PM photocatode, left arm: white spots – calculation, black spots – measurements. Scale in cm. First detector.*

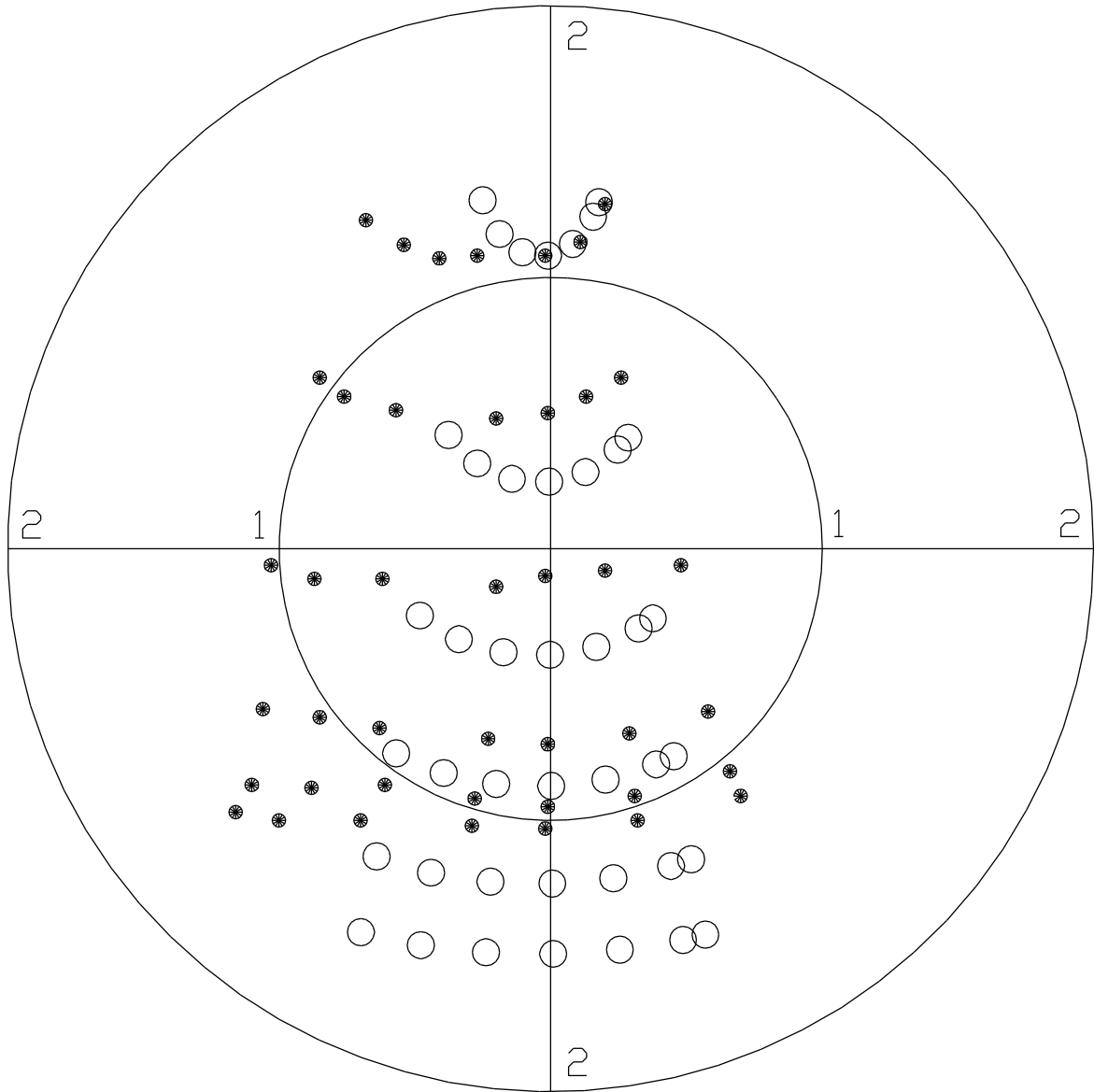

Figure 15: *Laser spots on the right top PM photocatode, left arm: white spots – calculation, black spots – measurements. Scale in cm. First detector.*

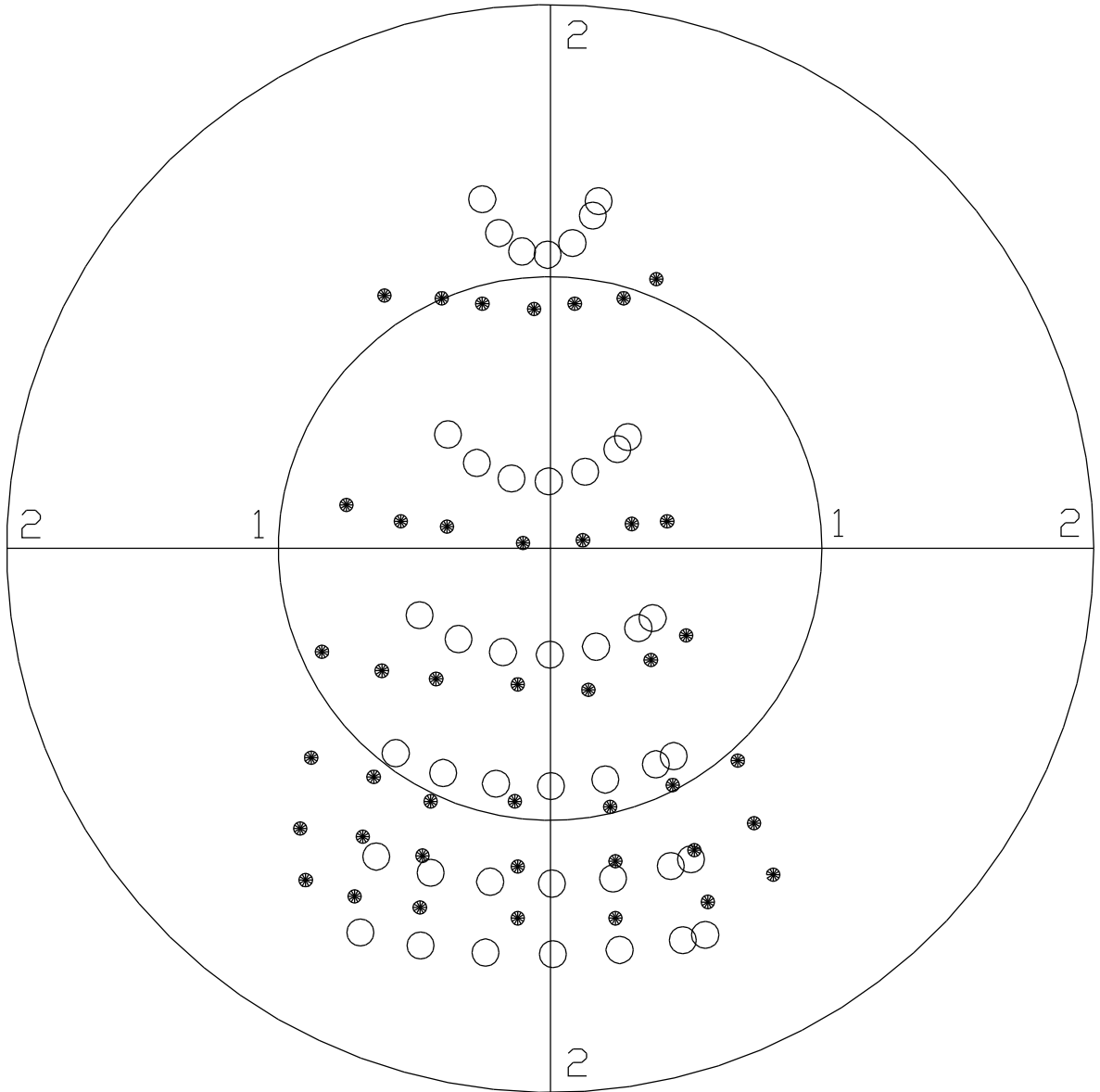

Figure 16: *Laser spots on the left bottom PM photocatode, left arm: white spots – calculation, black spots – measurements. Scale in cm. First detector.*

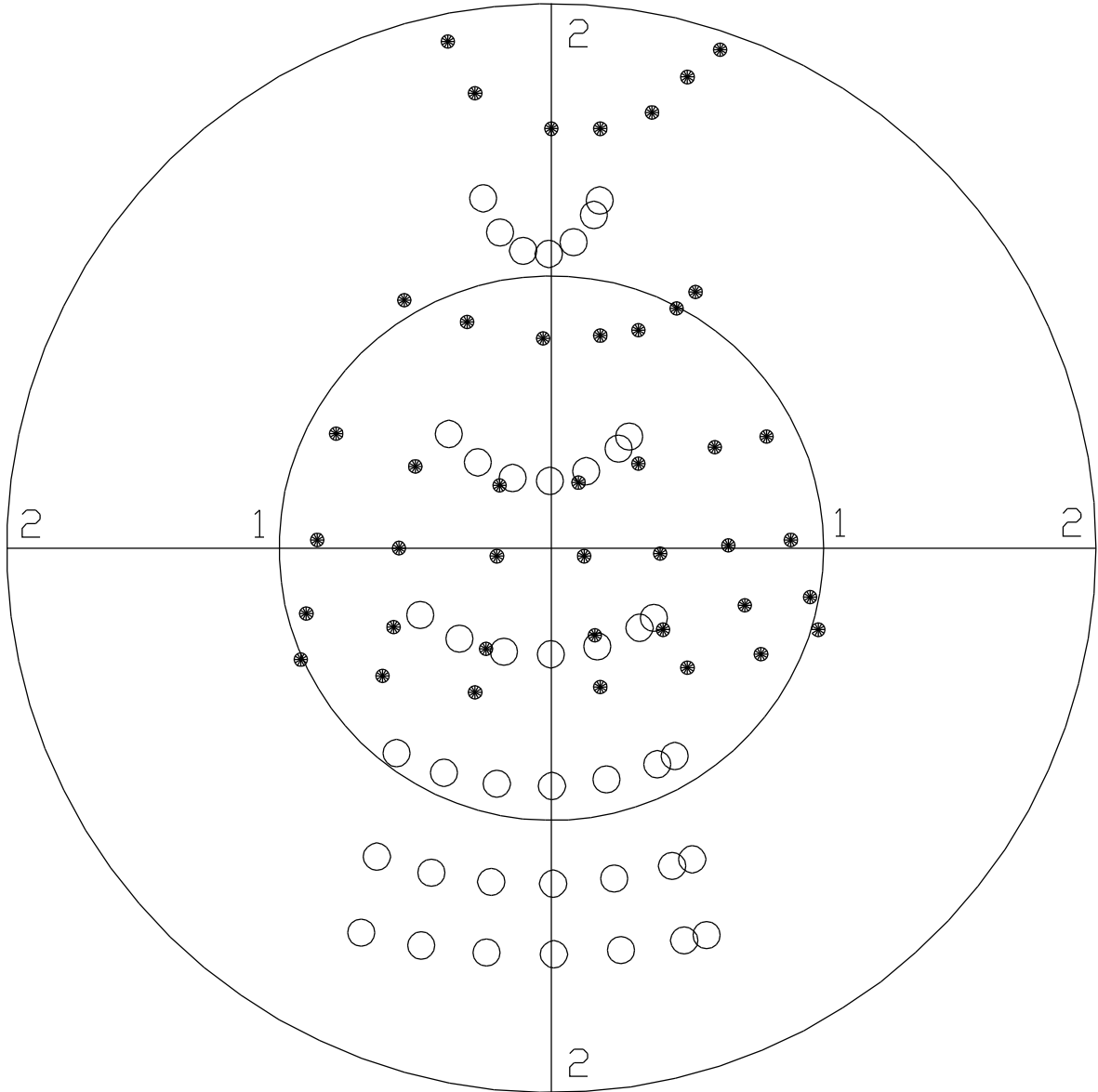

Figure 17: *Laser spots on the right bottom PM photocatode, left arm: white spots – calculation, black spots – measurements. Scale in cm. First detector.*

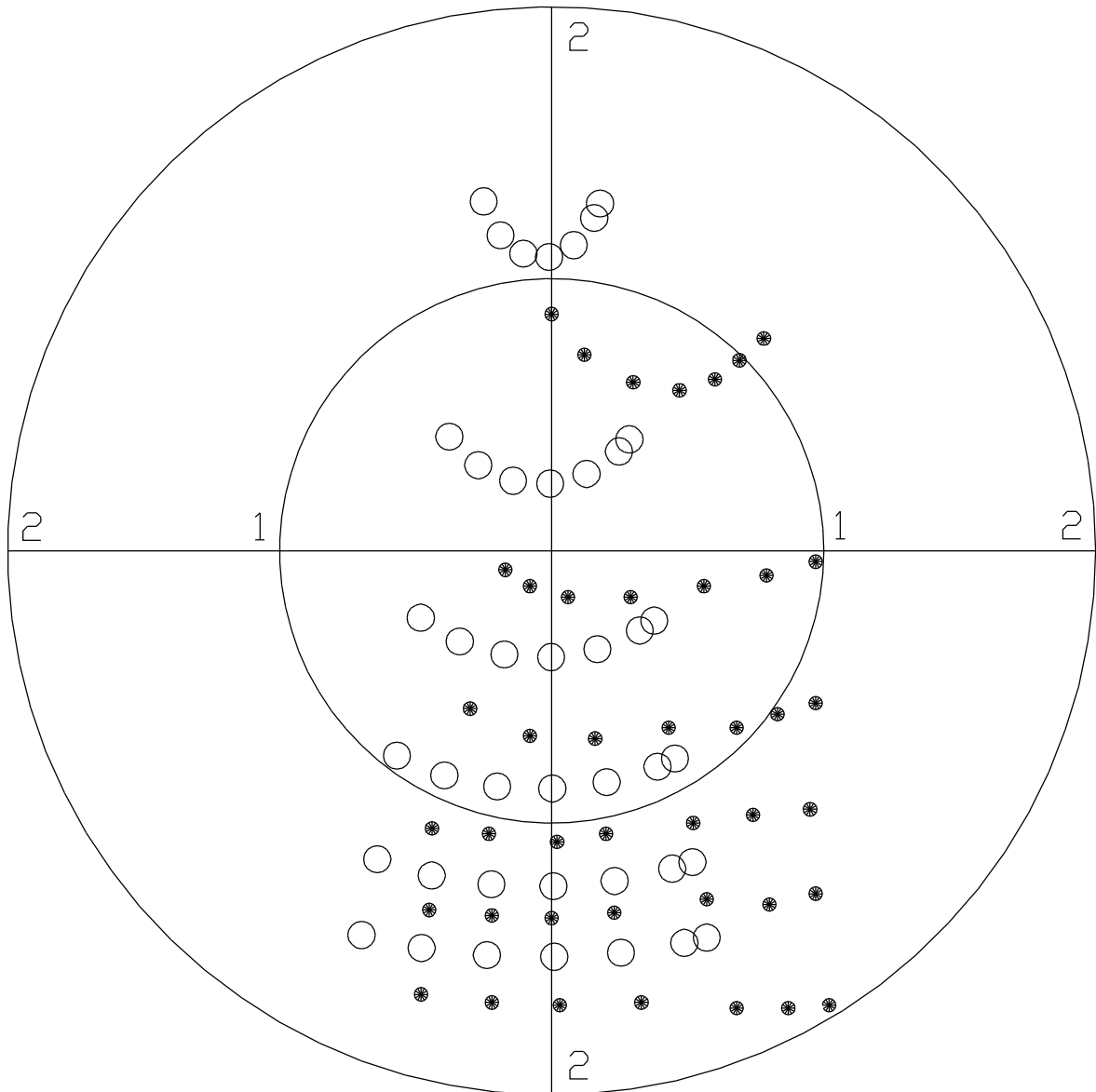

Figure 18: *Laser spots on the left top PM photocatode, right arm: white spots – calculation, black spots – measurements. Scale in cm. Second detector.*

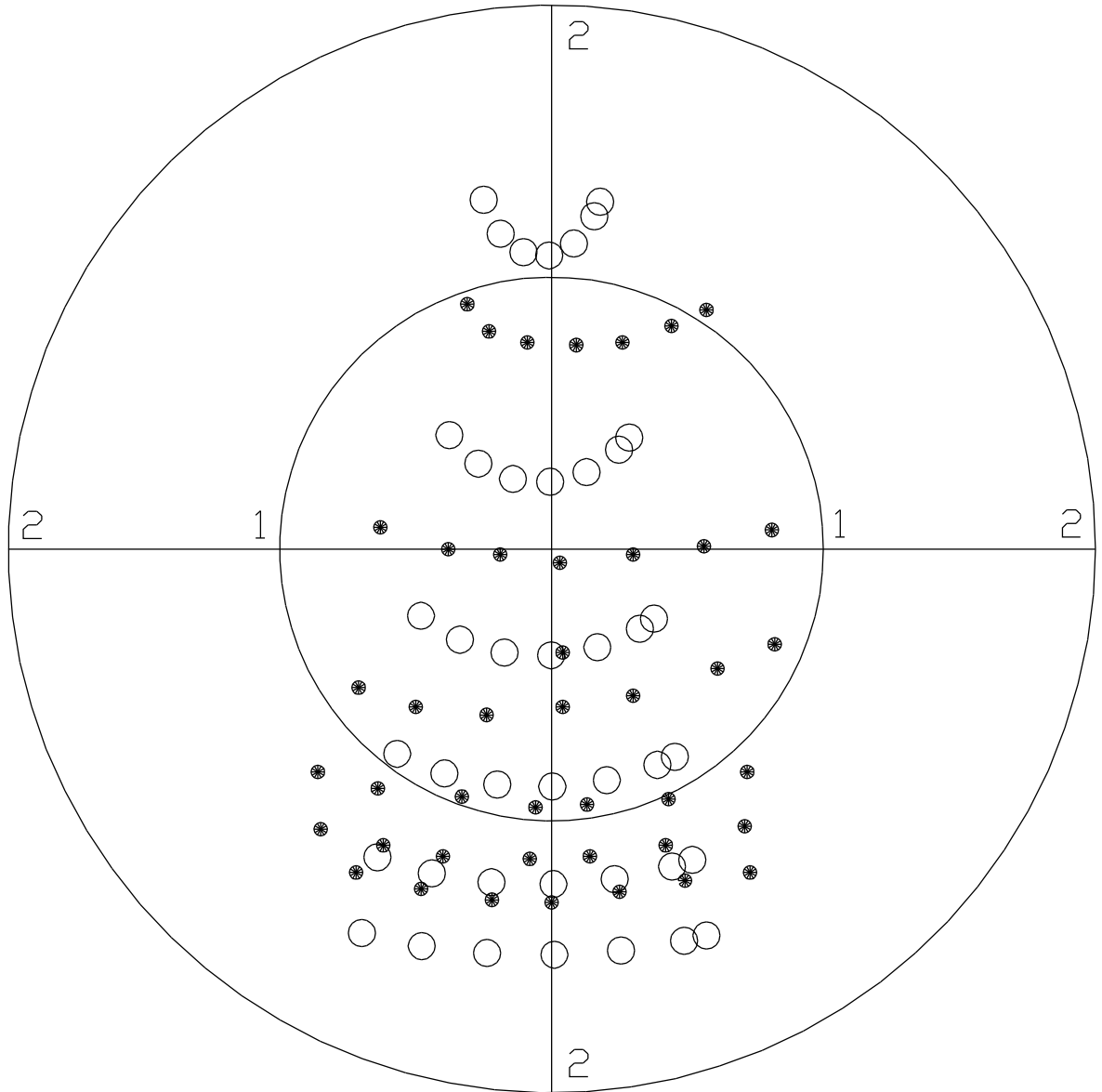

Figure 19: *Laser spots on the right top PM photocatode, right arm: white spots – calculation, black spots – measurements. Scale in cm. Second detector.*

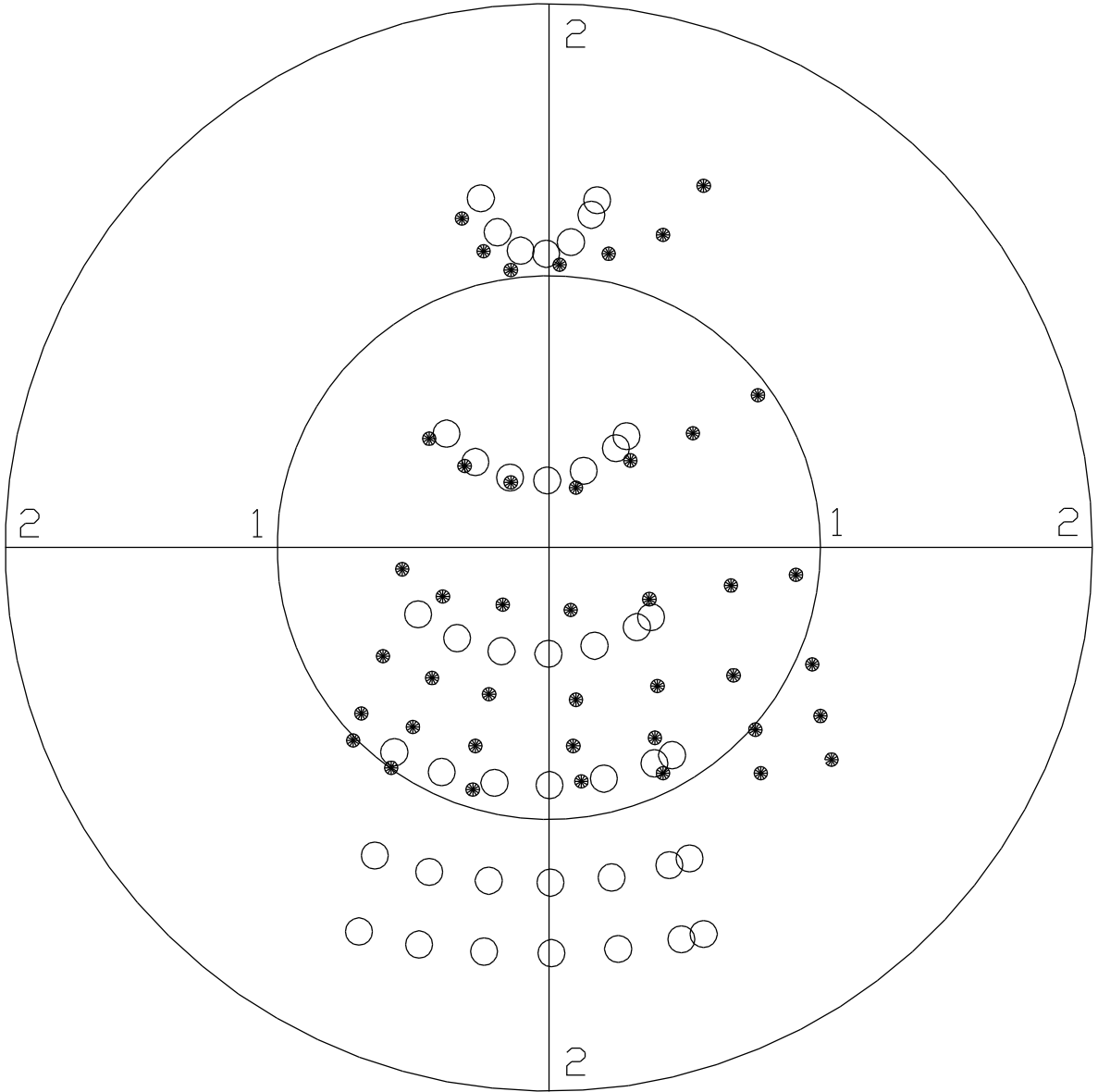

Figure 20: *Laser spots on the left bottom PM photocatode, right arm: white spots – calculation, black spots – measurements. Scale in cm. Second detector.*

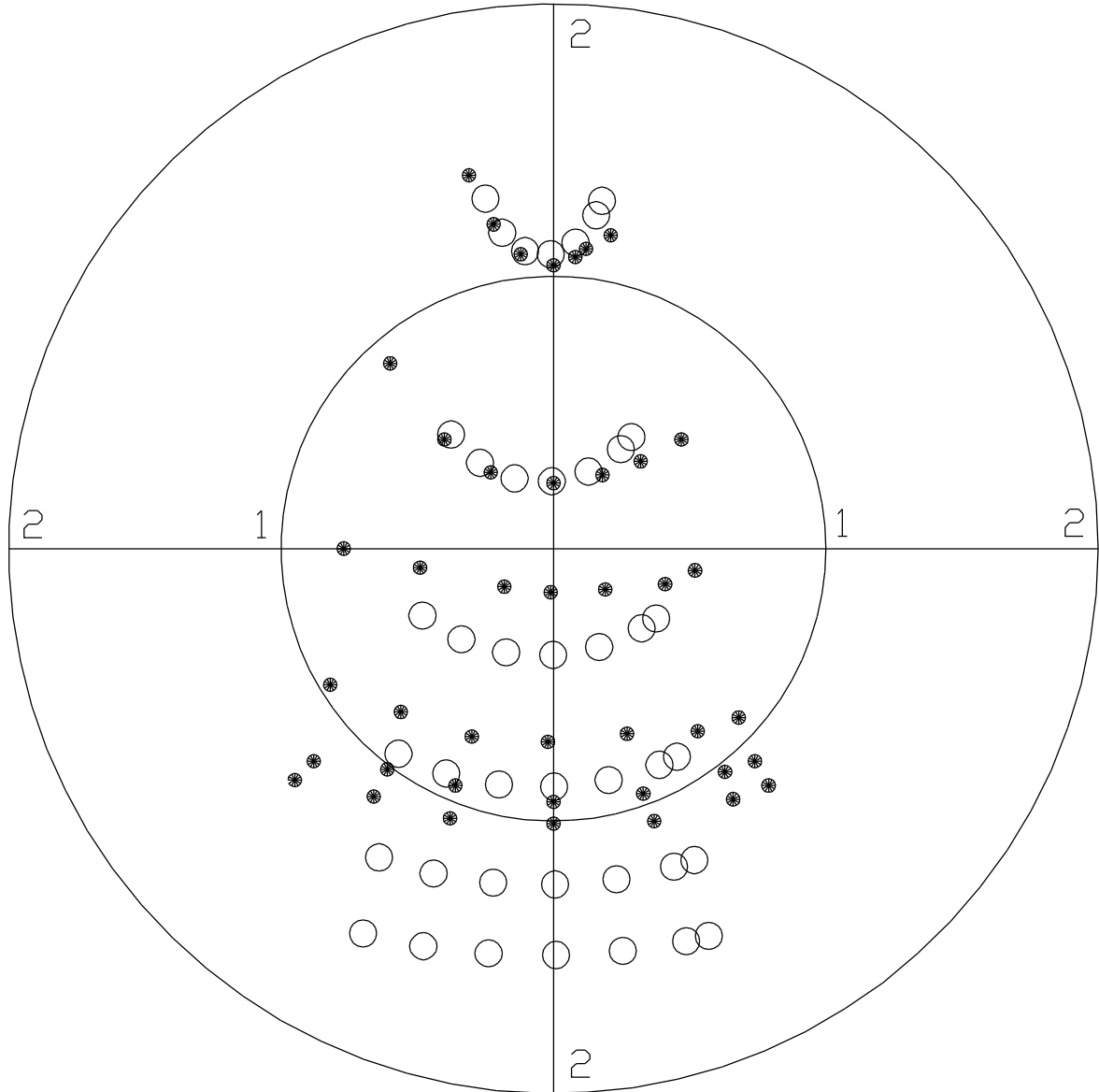

Figure 21: *Laser spots on the right bottom PM photocatode, right arm: white spots – calculation, black spots – measurements. Scale in cm. Second detector.*

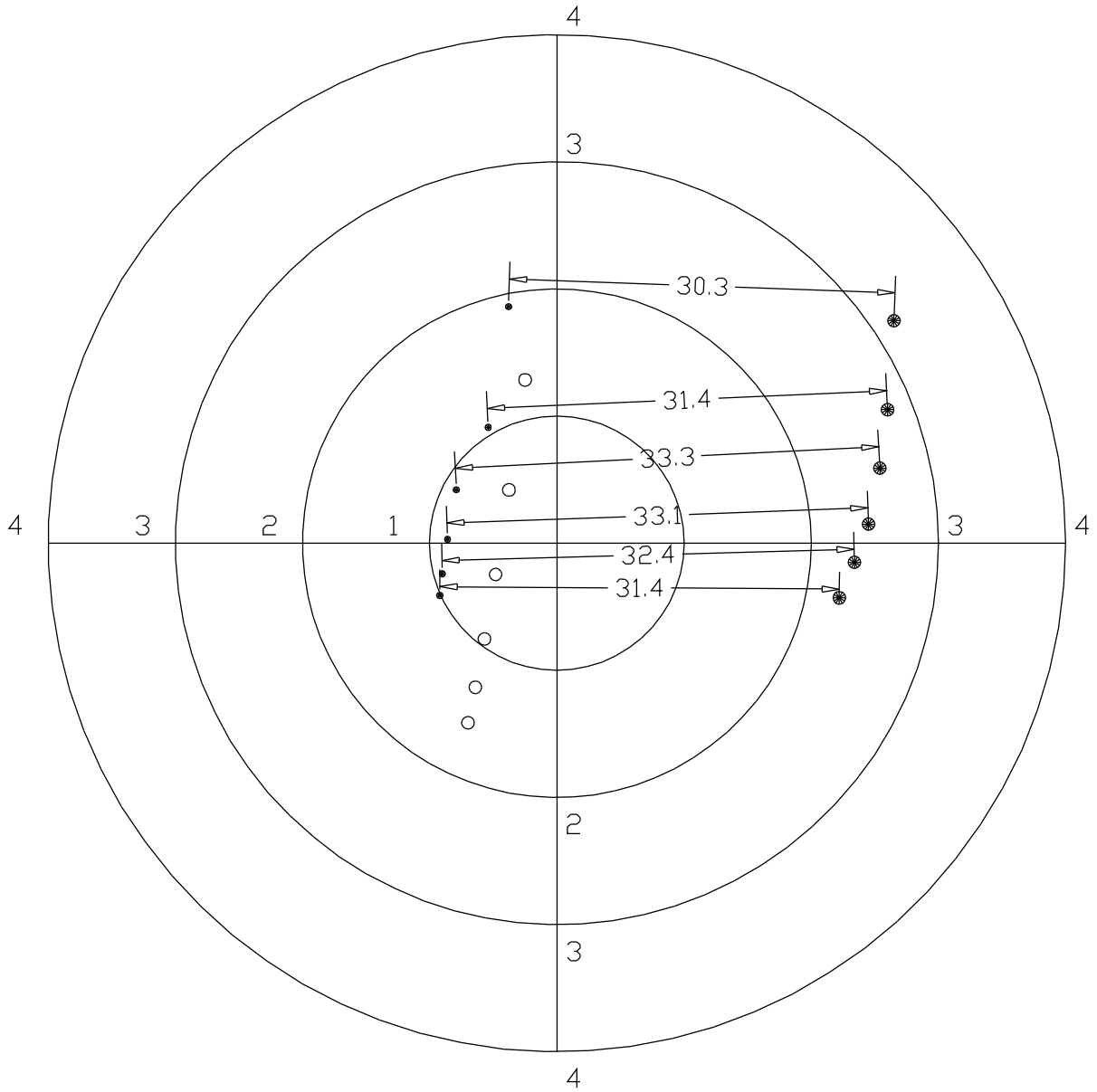

Figure 22: *Laser spots on the right bottom PM photocatode (first detector) from laser light imitating kaon beam (white spots – calculation, black small spots – measurements) and laser light spots imitating Cherenkov light (black big spots – measurements). Scale in cm.*

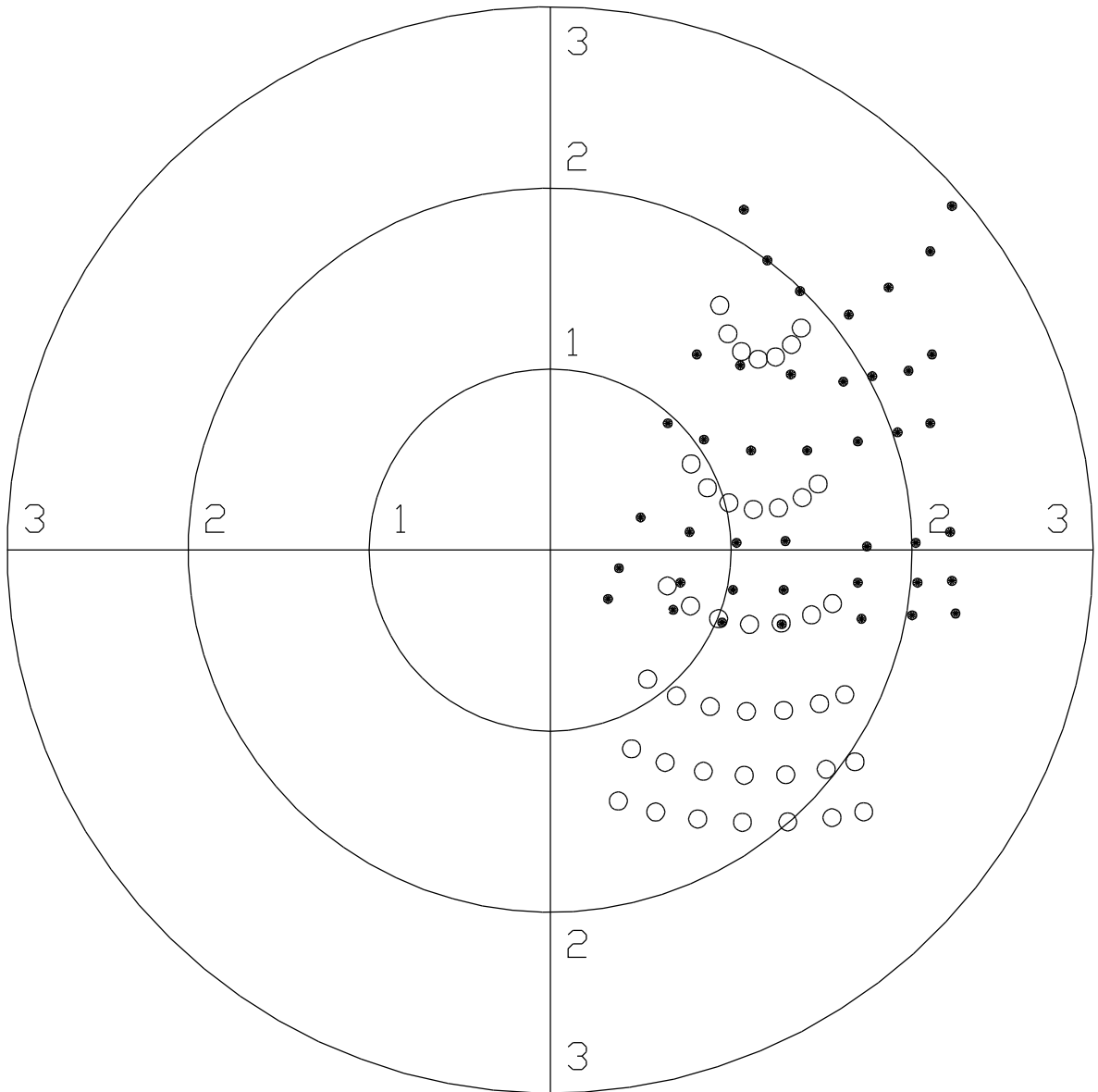

Figure 23: *Laser spots on the right bottom PM photocatode, (first detector): white spots – calculation, black spots – measurements. Scale in cm.*