

AX-PET DAQ/Analysis meeting 18/3/09 – 28-R-015

Present: V.Fanti, W.Lustermann, A.Braem, P.Solevi, C.Casella

Agenda:

- Wed Meeting next week
 - Analysis update: Light yield from WLS
 - Scanning measurements in Bld 304
 - DAQ status update
-

Wed meeting next week (25/3/09): cancelled.

Analysis update (WLS Light yield) :

- Effect found in the data: At full energy deposition (511 keV) the total light yield in the WLS (summed over all WLS interested by the event) grows linearly with the number of WLS interested by the event

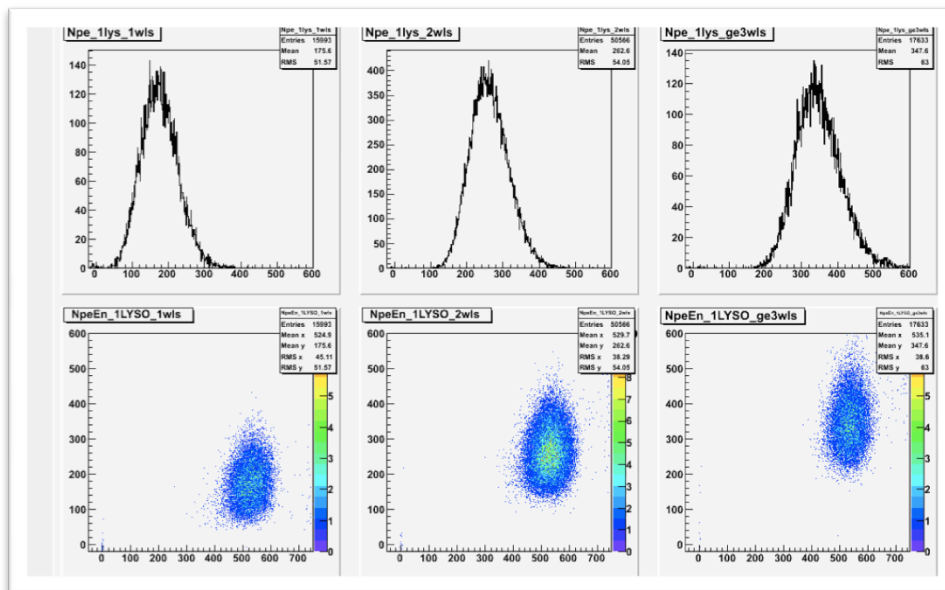

- This trend is also confirmed by simulations (Paola)
- The effect is not understood for the moment. More simulation studies would be very useful.

Preparation of the scanning measurements in Bld 304

a) General

The scanning measurements (y-z plane) in Bld 304 are intended as “fine tuning” measurements on the full module, with good potentiality of adding new

knowledge to the detector. They foresee to use the module in coincidence with a small tagging scintillator (2x2x12 mm³ LYSO crystals provided by Dieter Renker ; 5-7 small crystals will be available), with an automatic procedure for the movement of the tagging crystal on the y-z plane.

These scanning measurements will come as a final step, after several other measurements on the module, both of intrinsic radioactivity and with a big tagging scintillator.

A precise list of the measurements we want to perform must to be compiled (everyone is welcome to contribute).

b) Scanning measurements – general considerations

Main information already available from the measurements on 2x8 setup:

- energy calibration (averaged over the full crystal length)
- energy resolution (averaged over the full crystal length)
- hints for z-reconstruction. There are however some doubts on how the z-resolution information can be indirectly extracted from the distribution of the reconstructed z coordinate (the exact entry point of the gamma is not known).

Main information that could be added by the scanning measurements :

- $E(z)$
- $R(z)$
- z-resolution
- detection of possible distortion in the z-reconstruction due to non uniformity in the WLS (plus implement the correction)
- measure the detection efficiency
- possibility for a deeper study of ICS with the added knowledge of the interaction point.

Proposed measurements:

- scanning of 80 points/crystal, pitch=1mm, from 10 to 90 mm in the z direction of each crystals
- 10 keVts in the photopeak for each point
- the exact distance module – source has still to be defined. Two main factors to be considered: accidentals and rate
- dedicated studies (on few crystals) when the gamma entry point is very close to the MPPC and the opposite side

c) Mechanics layout

Andre proposes the design (see fig) for the module housing (light tight enclosure) and for the structure for the tagging scintillator + PMT.

Suggested needs / improvements :

1. Possibility to easily switch from big to small tagging scintillator. Three possibilities should be foreseen : (a) 20x20x20 mm³ (b) 2x2x12 mm³ i.e. one small lyso (c) 10x2x12 mm³ i.e. 5 small lyso.
2. Foresee an easy handling of the source - The exact dimensions of the sources available must be known (Andre needs this input)
3. Pb (or anything else) screen for radioprotection

4. Ensure a conductive light tight enclosure
5. Allow for automatic scanning in the y-z plane with remote controlled scanning tables + rails to adjust the distance btw the module and the source (the latter position, once defined, will be fixed).

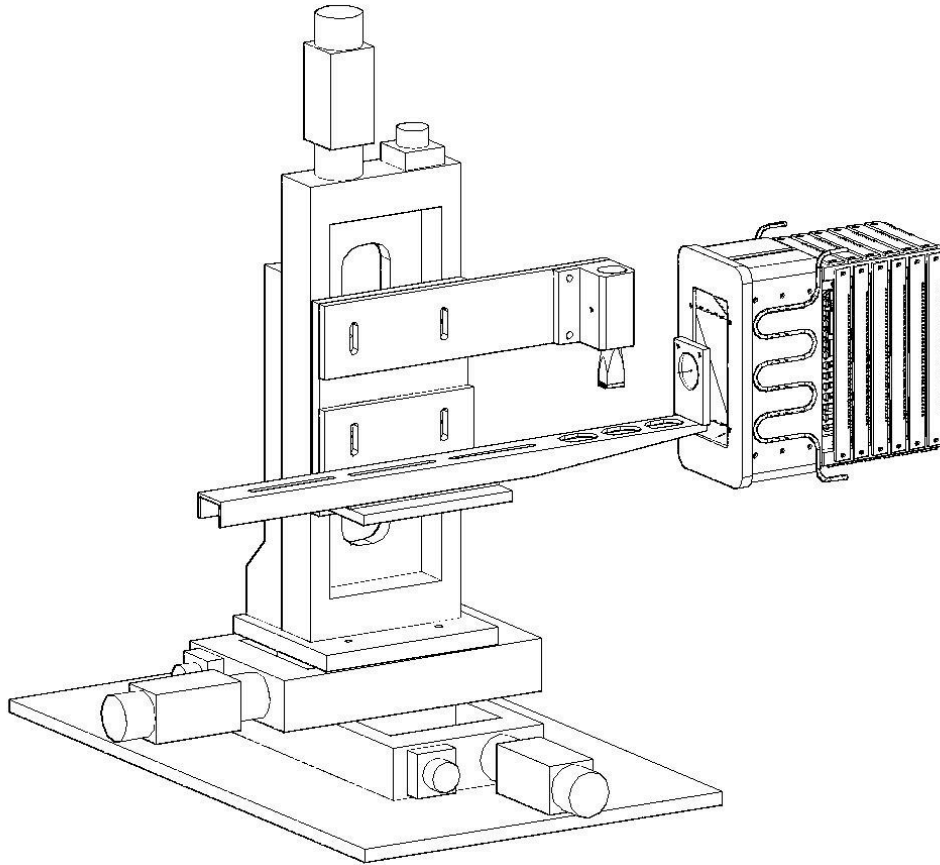

DAQ status update

- Full readout for the 2 modules is ready to be moved in Bld 304.
- A HW problem was found and solved (3 resistors missing in the intermediate boards) – needed modification now implemented in all available intermediate boards.
- Next task : communication and hand-shaking between DAQ PC & Slow Control PC: DIM as suggested solution